

A photograph of a modern retail clothing store. The background is a wall of vertical wood slats. In the foreground, there are several clothing racks. On the left, a rack holds a light blue button-down shirt and a dark grey shirt. In the center, a rack holds a row of shirts in various colors (dark grey, light blue, white). On the right, a white button-down shirt is displayed on a hanger. A black track lighting fixture is mounted on the wall above the racks.

Retail Display Solutions

MODULAR | FREESTANDING | CUSTOM

 **ALLUX**

www.al-lux.com

Retail Display Solutions

MODULAR | FREESTANDING | CUSTOM





Contents

- Modular retail shelving systems 5**
- Partition shelving systems 7
- Wall shelving systems 13

- Display elements for modular shelving systems 24**

- Freestanding retail shelving 33**
- Freestanding metal shelving 34
- Assembly 64 34
- Freestanding wood shelving 36
- Assembly 72 36
- Miscellaneous shelving 40

- Retail Display Stands 43**
- Assembly 63 45
- Assembly 65 49
- Assembly 66 52

- Custom Solutions 55**

Modular retail shelving systems

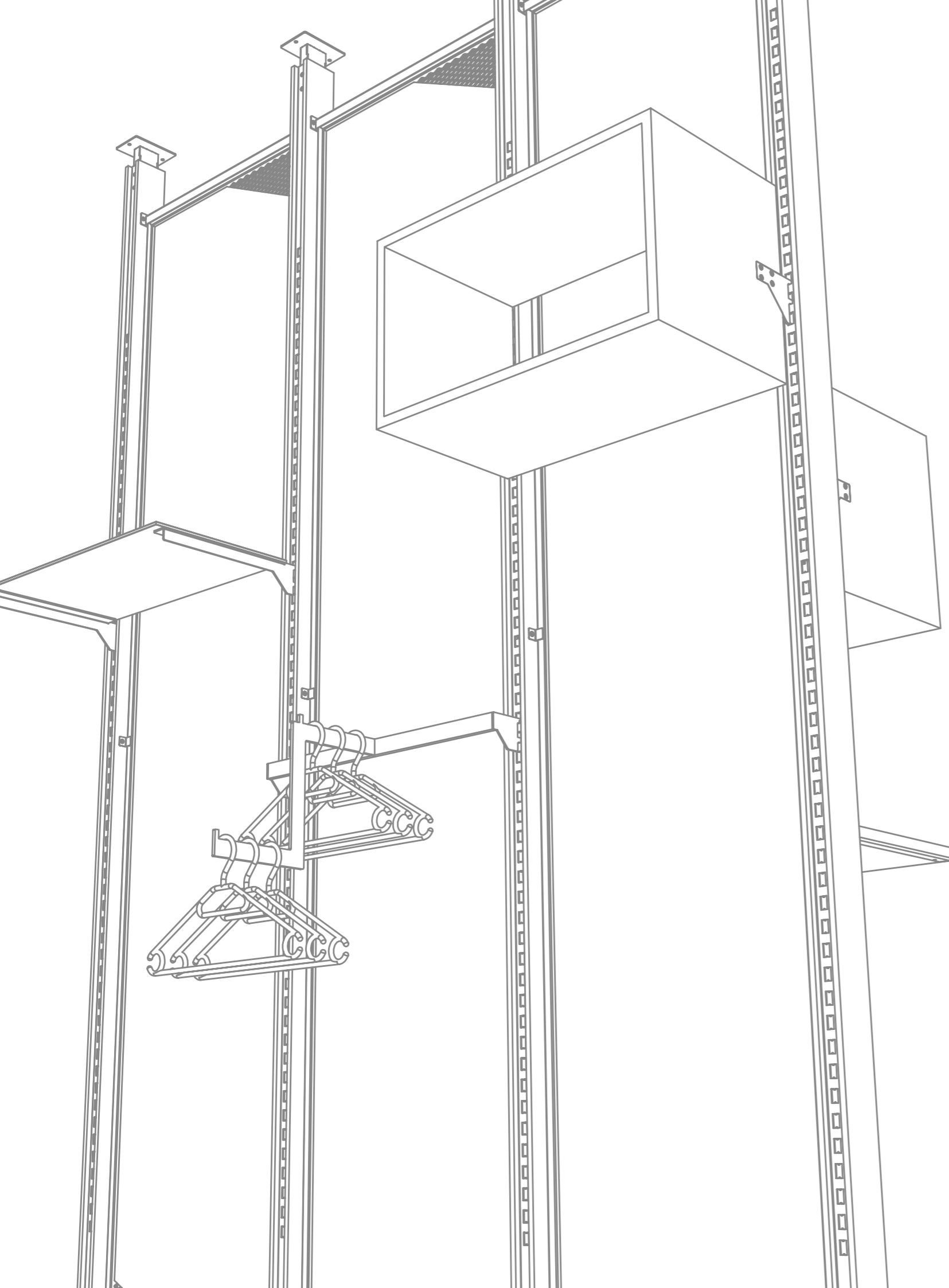

Partition shelving systems

Explore our unique collection and find the right shelving system for your store. Al-Lux manufactures unique shelving systems with movable, height - adjustable shelves and clothing rails for exhibiting clothes, garments, uniforms and other products in retail stores and boutiques.



This system makes the most use of the presenting area and it is adaptable to any clients vision or project. The dimensions of the system and combinations of shelves are adaptable to any interior.

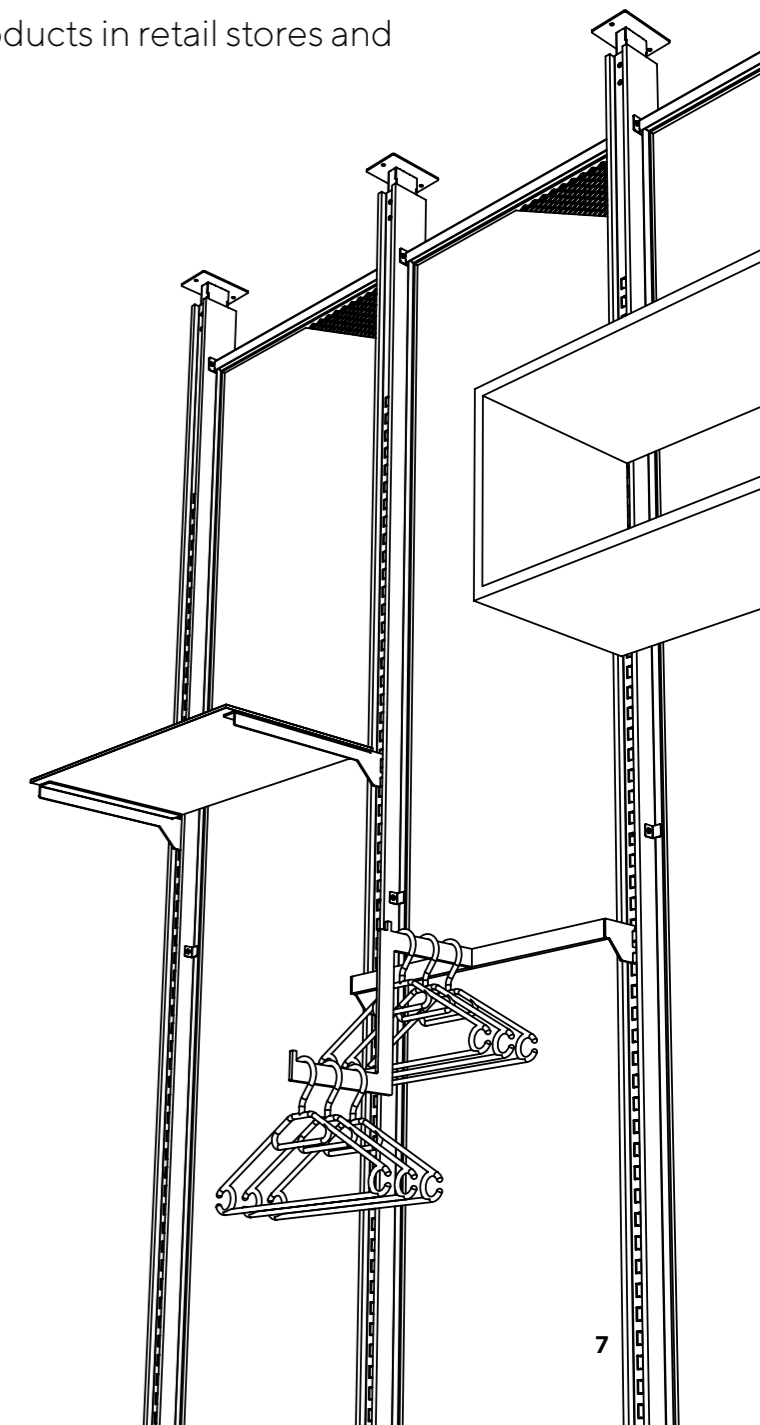

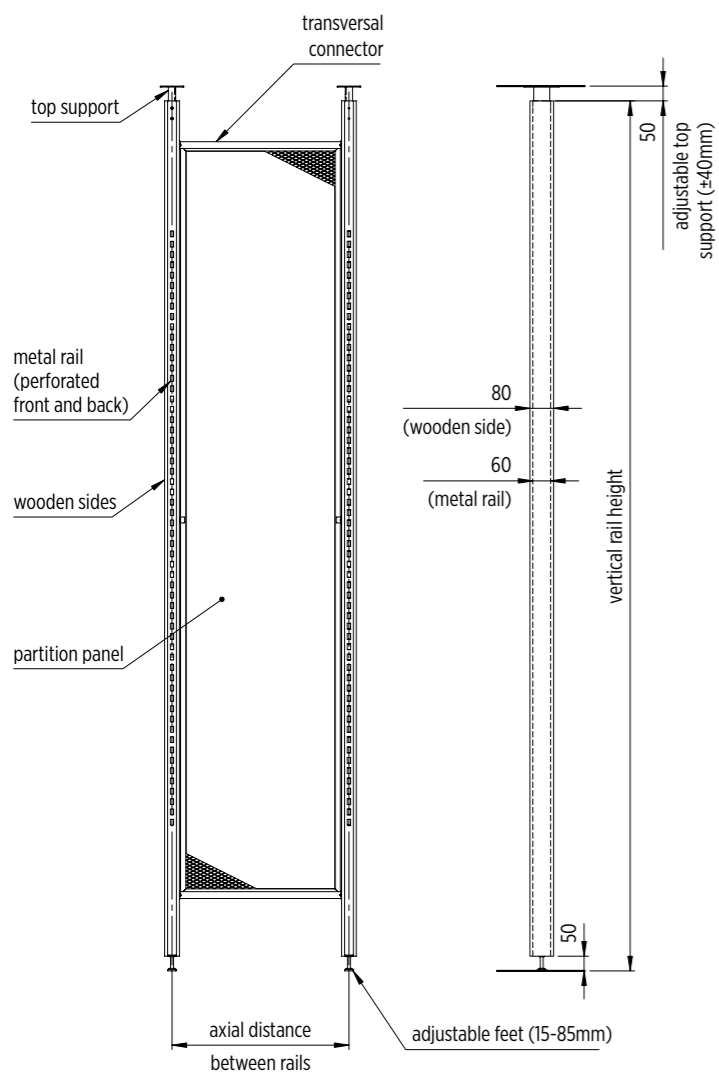

■ 600mm vertical rails axial distance

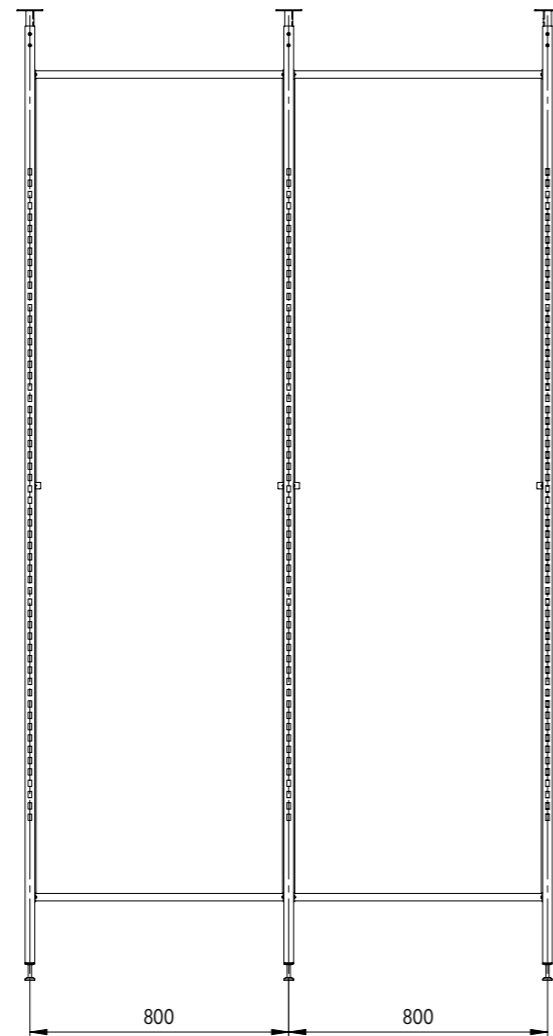

■ 800mm vertical rails axial distance. Option without wooden sides.



This modern solution ensures that your space will be highly aesthetic, stylishly recognizable, functional and perfectly tailored to the needs of your business.



DESIGNATION / ORDERING CODES

SPS - 2950 - MM - WS - 600 - 3 - 1

1 2 3 4 5 6 7

1 **SPS** : Shelving Partition-mount System

2 **2600 - 2950** : Vertical rail height (in millimeters measured from floor). 2950 mm vertical rail supplied as a standard. Heights from 2600 to 2950mm available.

3 **MM** : Metal mesh partition
WB : Wood board partition
C : Custom layout of the partition panels

* Consult factory if custom layout of the partition panels is required

4 **WS** : Option with wooden sides.
X : Option without wooden sides.

5 **600 or 800** : Vertical rails axial distance in millimeters.

6 **2 or more** : Number of vertical rails

7 Surface finish options:
 1 : Raw/unfinished
 2 : Black (RAL 9005 matte)
 3 : White (RAL 9010 matte)
 4 : Anthracite (RAL 7016 matte)



The system contains structural vertical rails that can be manufactured to desired height. The rails can be powder coated metal or powder coated metal with wooden sides. Choice of intermediate panels from metal mesh to wood board gives desired appearance. Shelves and rails can be selected in the matching materials.



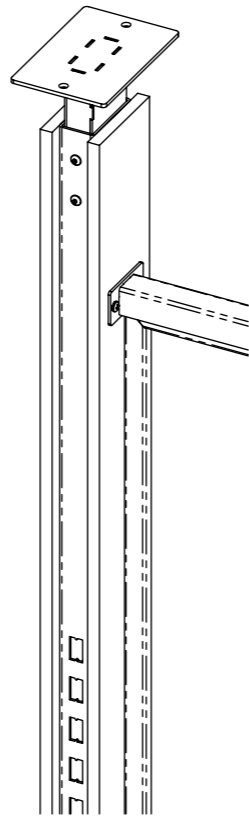

■ With wooden sides

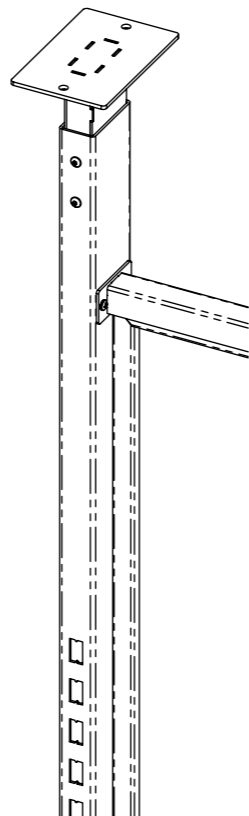

■ Without wooden sides

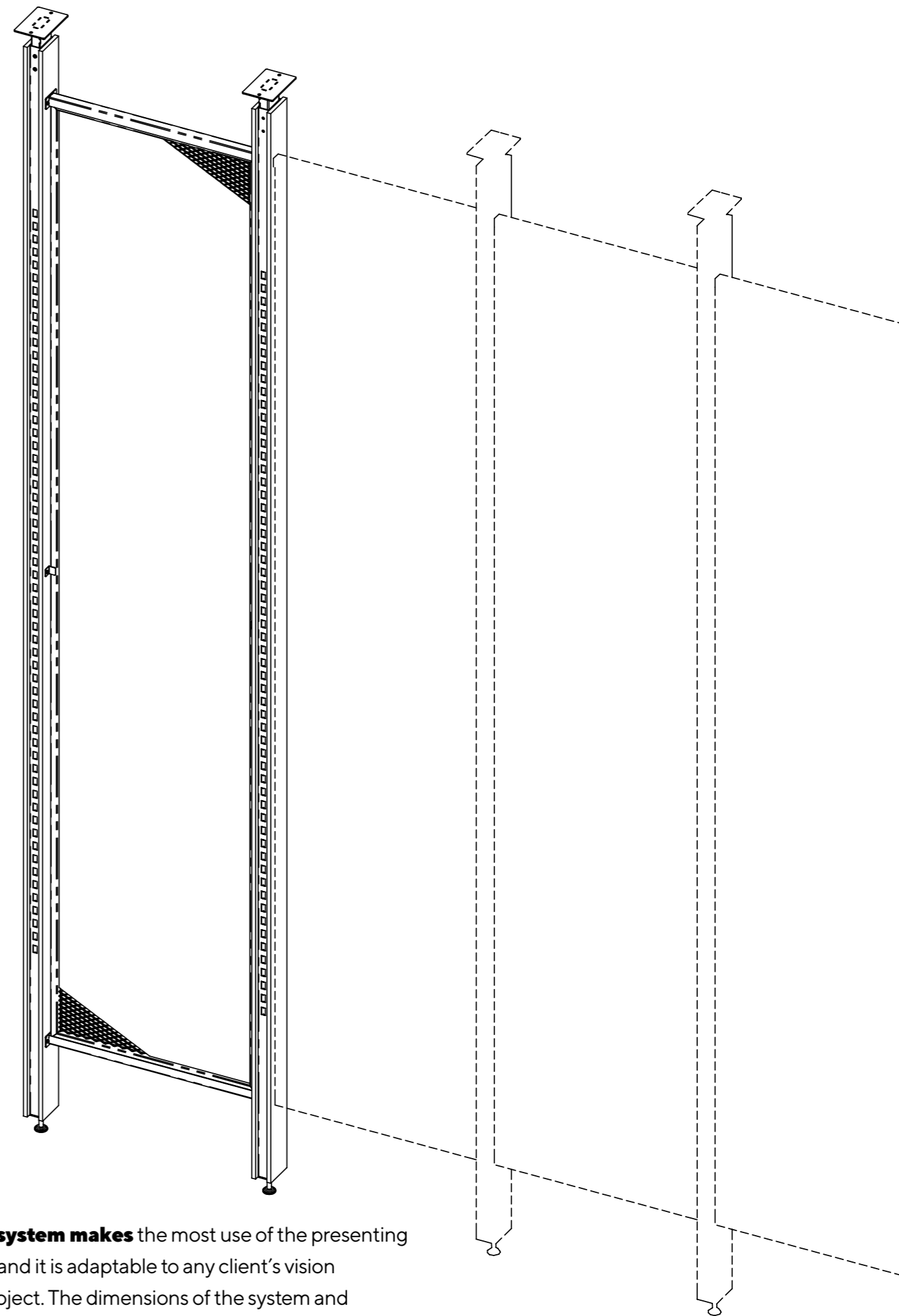

The system makes the most use of the presenting area and it is adaptable to any client's vision or project. The dimensions of the system and combinations of shelves are adaptable to any interior.



Wall shelving systems

The wall system contains wall structural elements installed on to a wall surface and a wide choice of shelves (wooden or glass) and rails for clothing that can be organized in numerous ways according to client's needs and creativity.

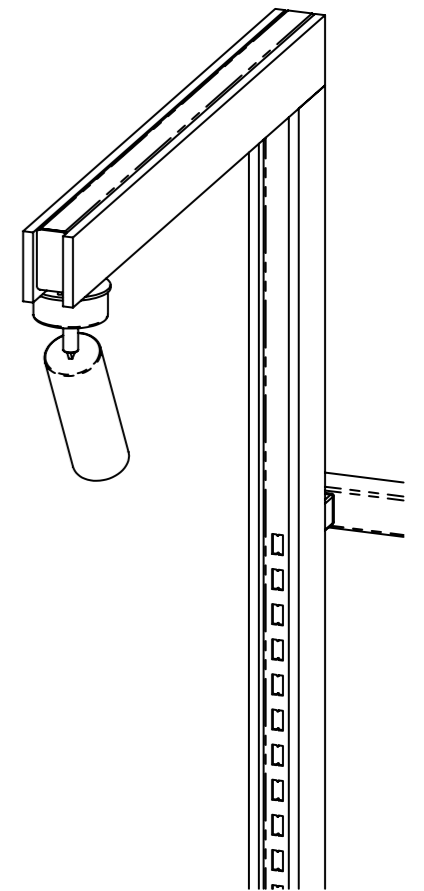



DESIGNATION / ORDERING CODES

SWS - 2950 - C600 - WS - 800 - L2 - 1 - MM

1 2 3 4 5 6 7 8

1 SWS : Shelving Wall-mount System

2 2600 - 2950 : Vertical rail height (in millimeters measured from floor). 2950mm vertical rail supplied as a standard. Heights from 2600 to 2950mm available.

3 C600 - C900 : Option with down light console (length in millimeters). 600mm console supplied as a standard. Lengths from 600 to 900mm available.

X : Option without down light console.

4 WS : Option with wooden sides.
X : Option without wooden sides.

5 600 or 800 : Vertical rails axial distance in millimeters.

6 Module type:
S_ : Single module... _2 : ...with two vertical rails
L_ : Left module... _3 : ...with three vertical rails
M_ : Middle module...
R_ : Right module...

7 Surface finish options:
1 : Raw/unfinished
2 : Black (RAL 9005 matte)
3 : White (RAL 9010 matte)
4 : Anthracite (RAL 7016 matte)

8 Fill-in panel options:
MM : Metal mesh fill-in panels
WB : Wood board fill-in panels
N : No fill-in panels
C : Custom layout of the fill-in panels

* Consult factory if custom layout of the fill-in panels is required

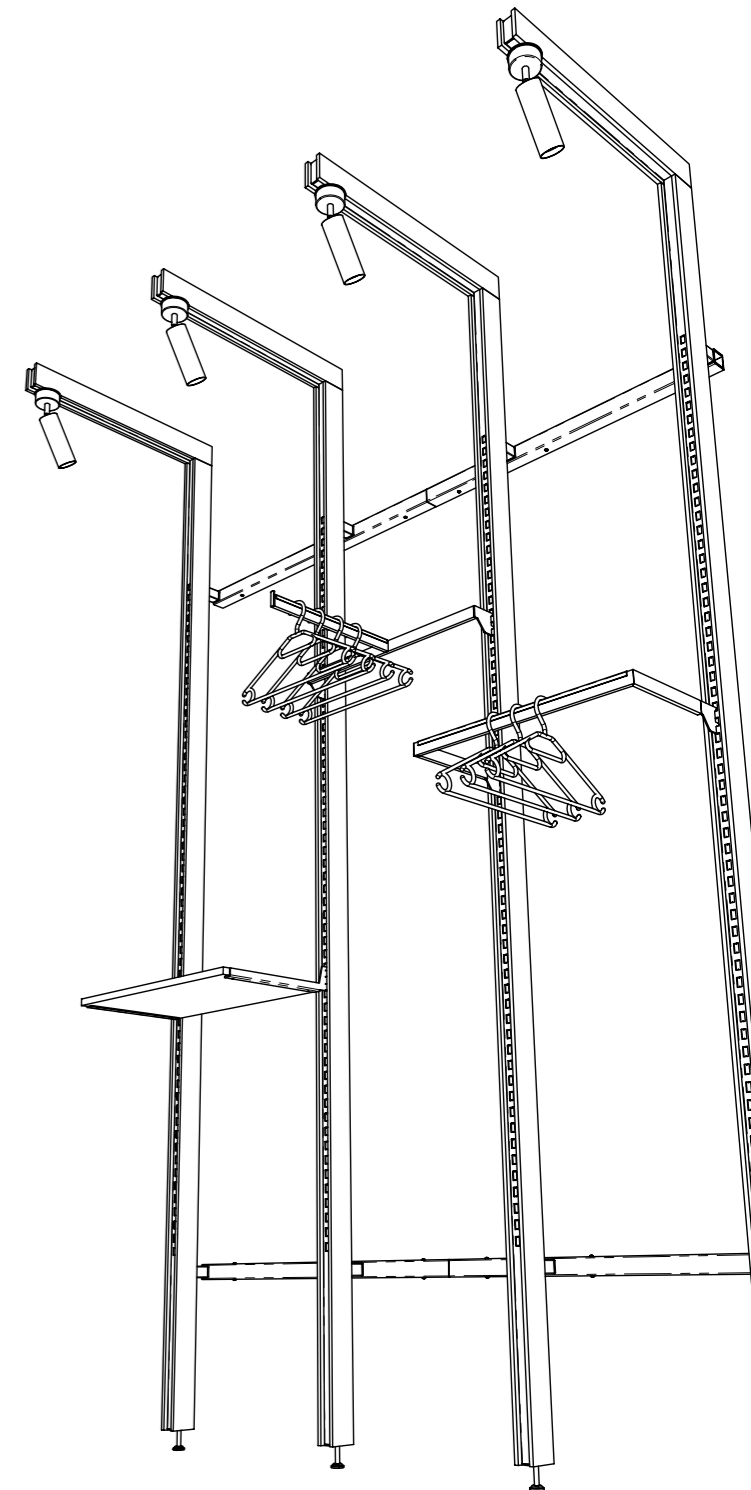

The dimensions of the system and combinations of shelves are adaptable to any client's vision or project.

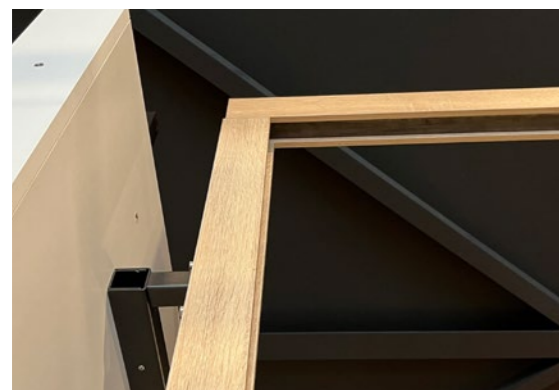

We can deliver a unique store fitting experience with high functionality and maximum use of retail space.



The vertical support rails can be powder coated metal or powder coated metal with applied wooden sides. You can choose intermediate panels from metal mesh to wood board or select other material.





Choose the combination of modules that will fit the interior of your store. For your project, we can manufacture modules that are connected in sections to desired length or separated.

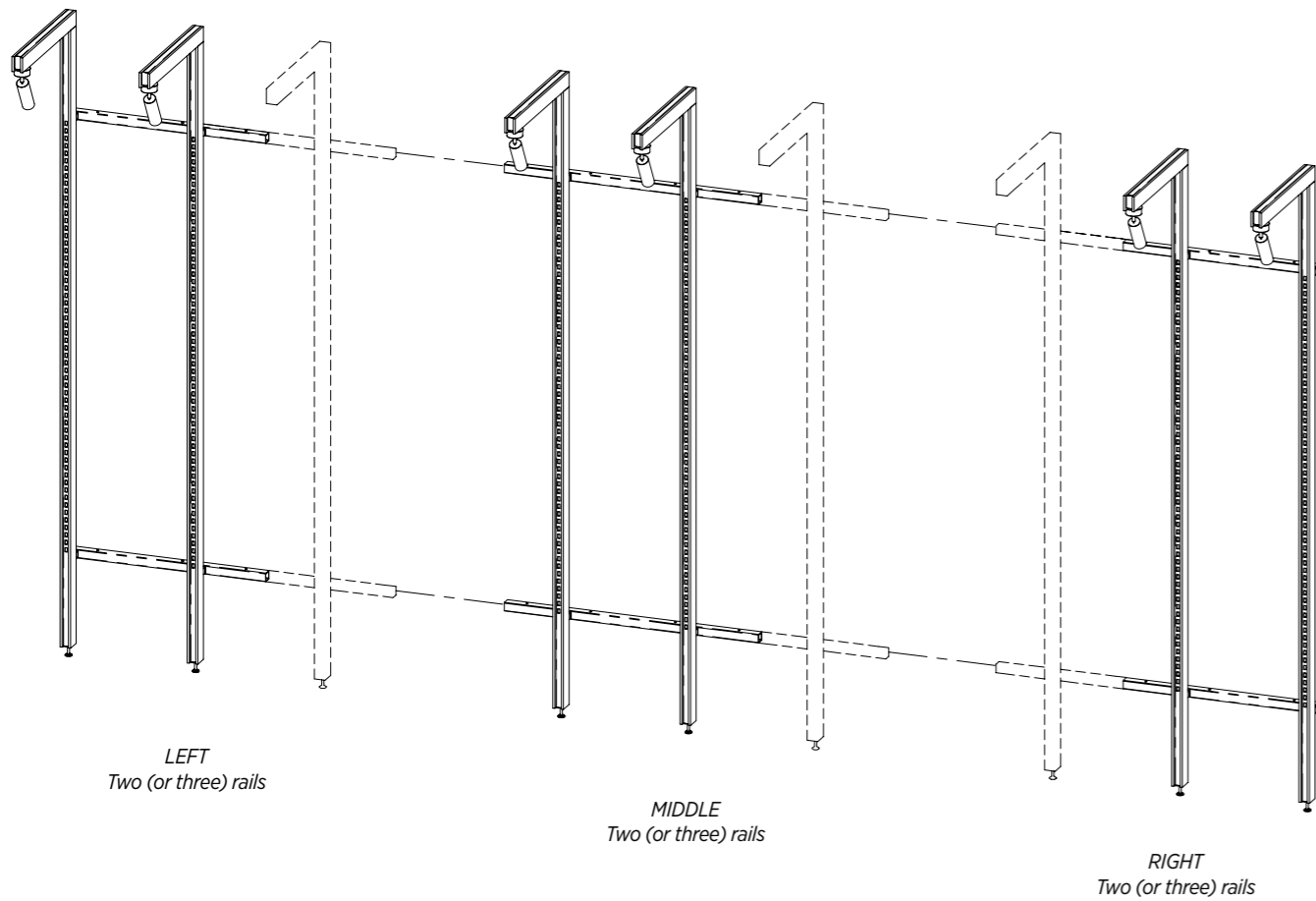

The dimensions of the system and combinations of modules are adaptable to any project. Review system's technical sheet for details, technical specifications, and dimensions.

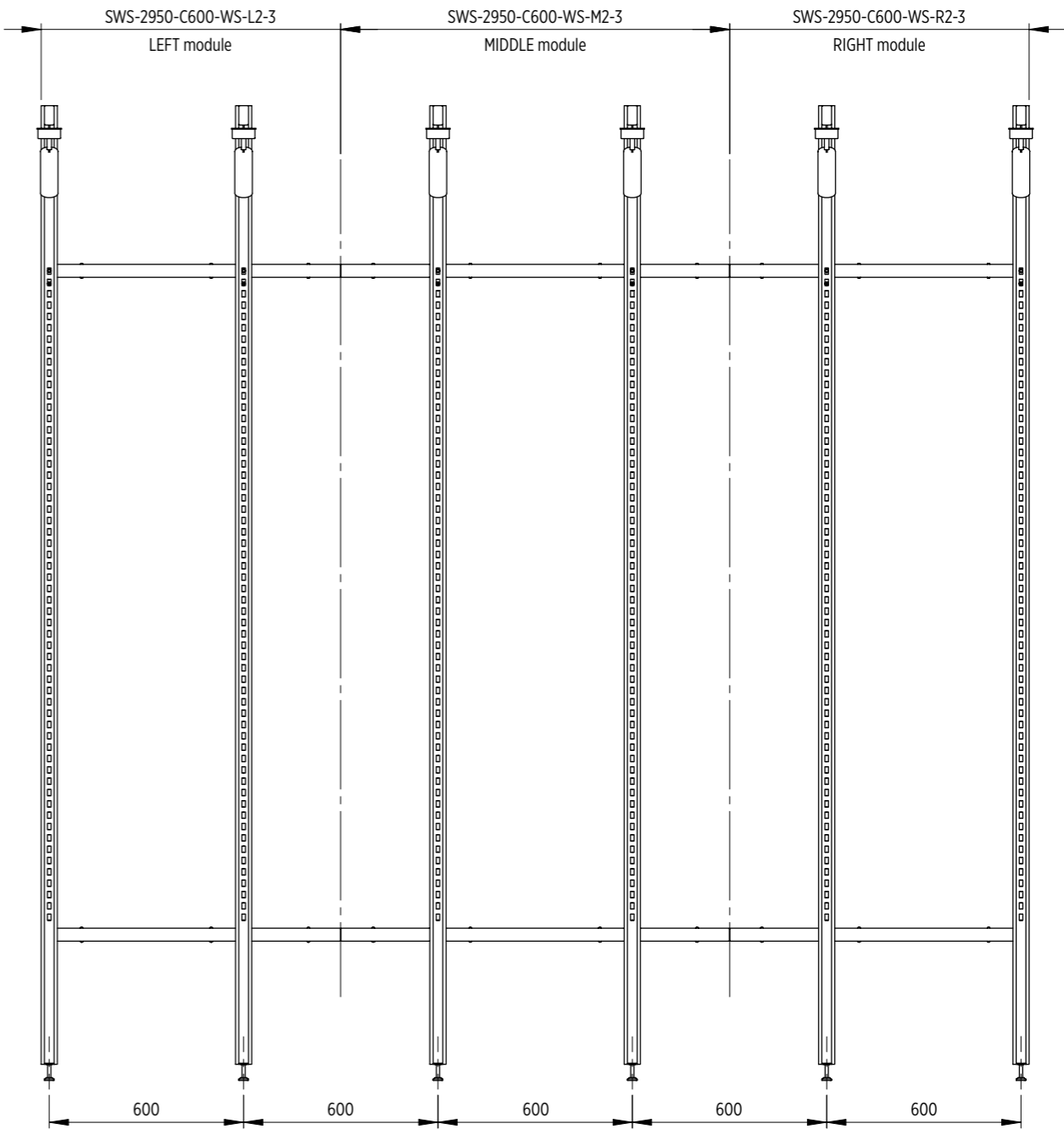
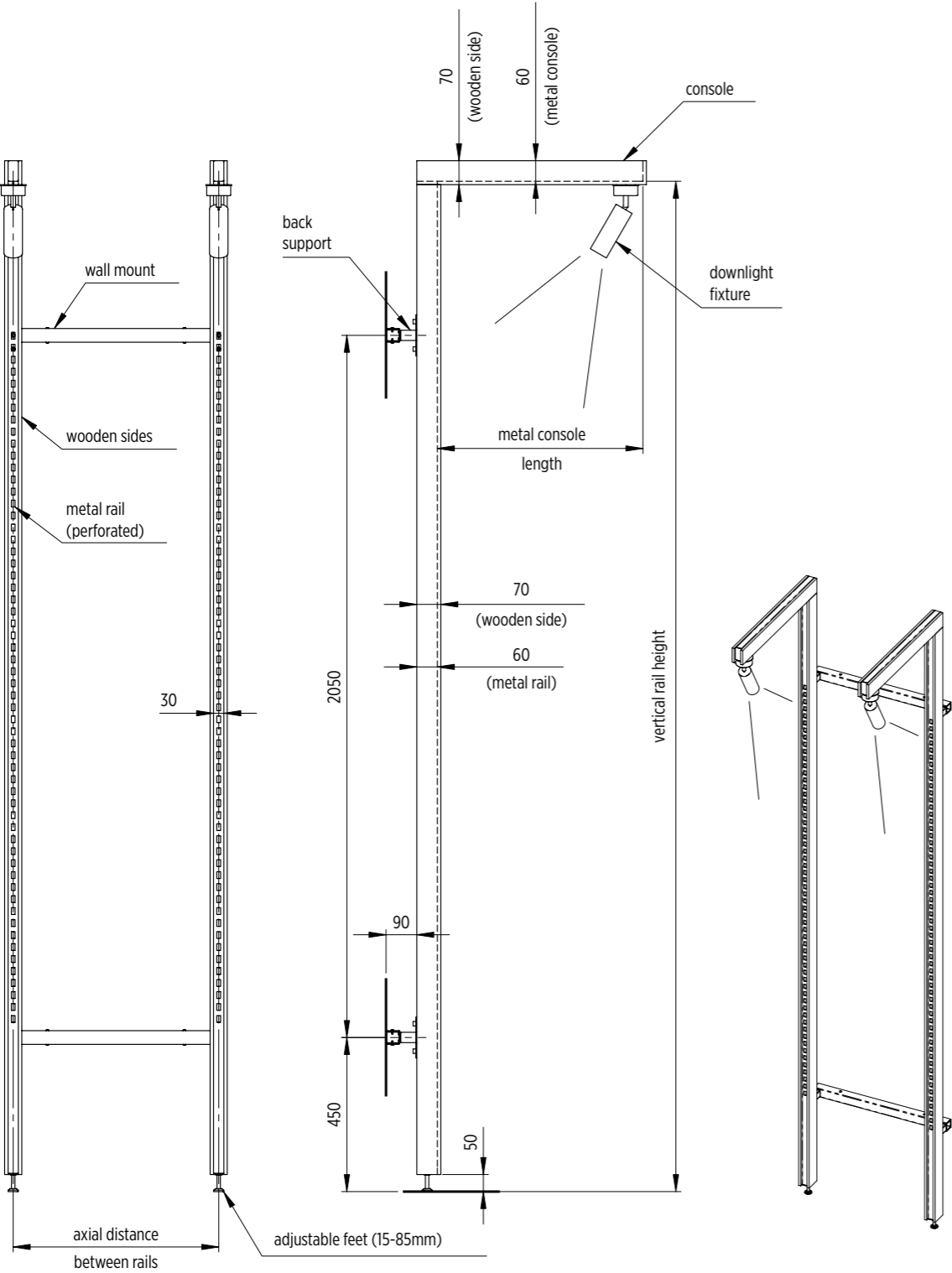

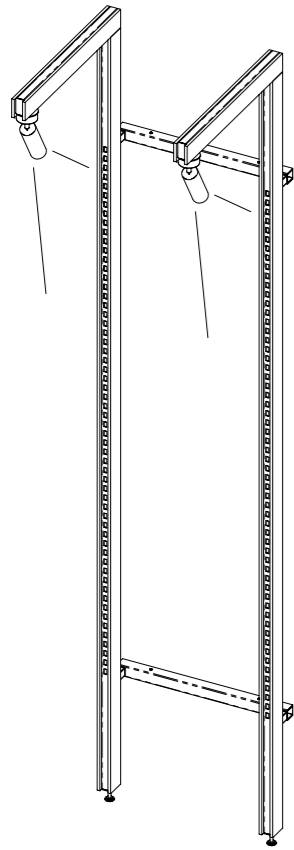

■ Model with downlight console

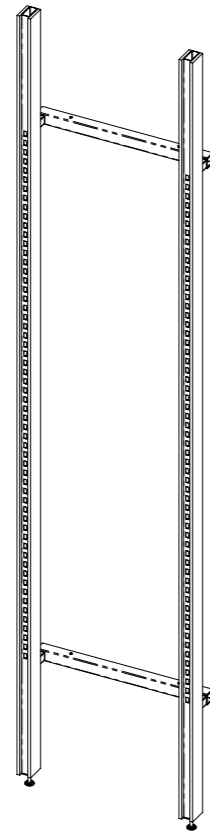

■ Model without downlight console

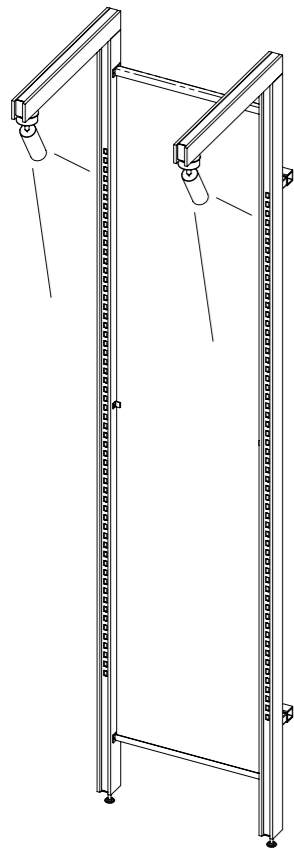

■ Model with wood board fill-in panel

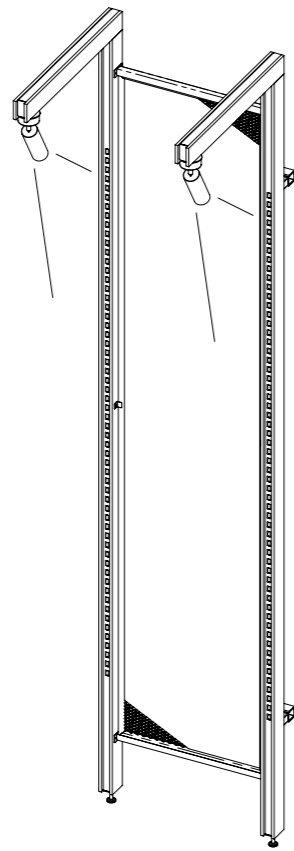

■ Model with metal mesh fill-in panel



Display elements for modular shelving systems

Select width of the display elements based on selected axial distance between vertical rails. Specify 600 or 800mm.

Wood shelf = WS

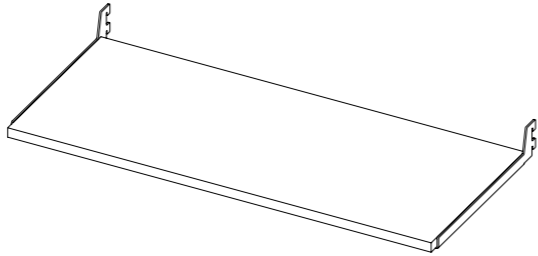

Glass shelf = GS

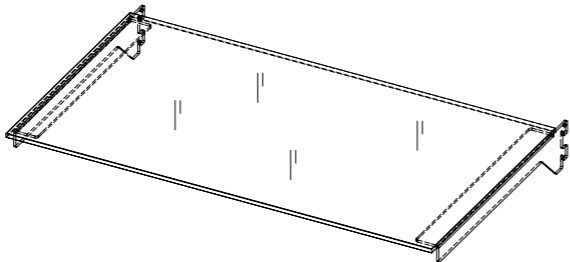

Wood box shelf = WBS

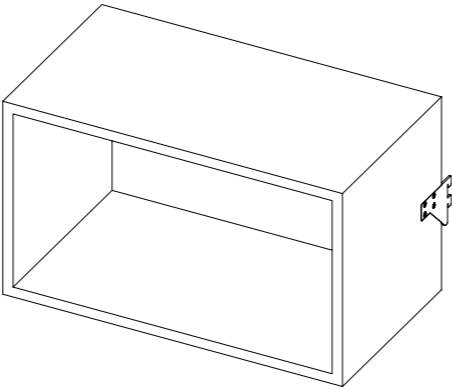

Hanger Support 1 = HS1

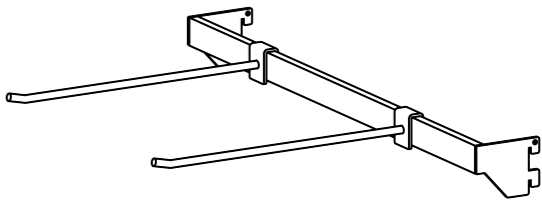

Hanger support 2 = HS2

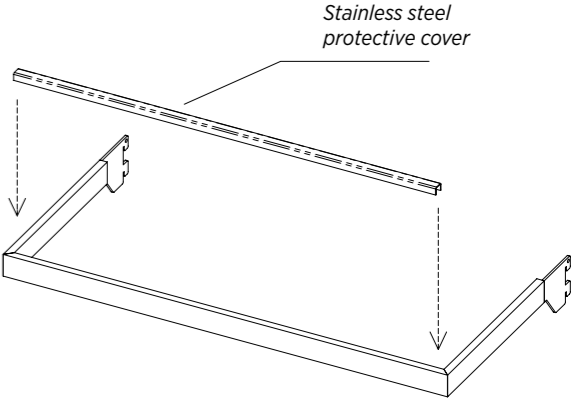

Hanger support 45 = HS45

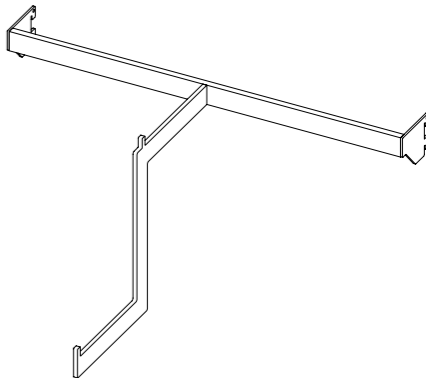

Hanger support 46 = HS46

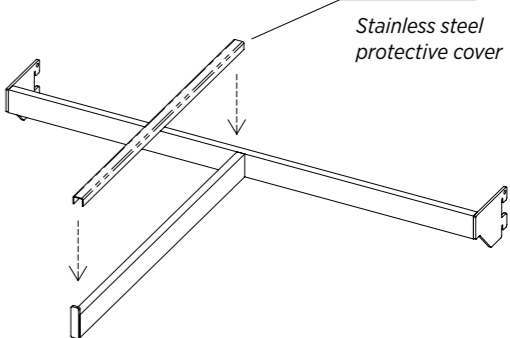

Display elements for modular shelving systems

We manufacture a wide choice of adjustable rails, shelves and hanger supports for displaying clothes, garments and uniforms. We can also manufacture custom rails as per client's request.

Wood shelf = WS

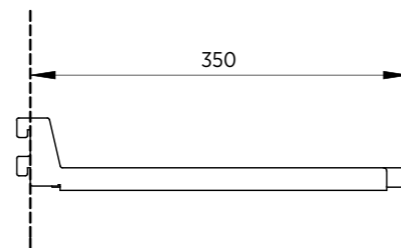
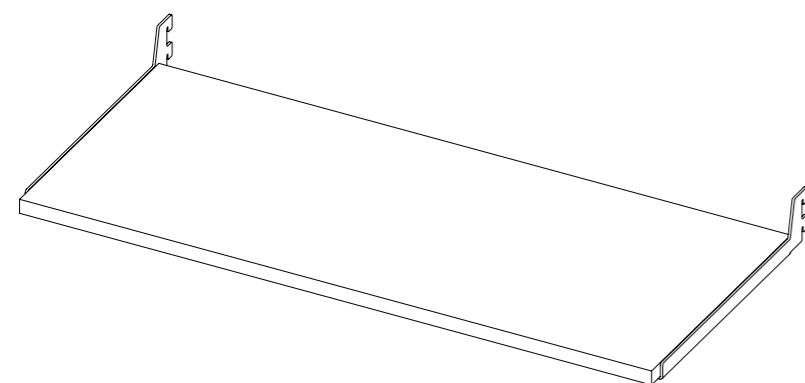

■ WS - 600 (800)

Glass shelf = GS

The shelves are made with options and combinations of wood, chipboard, glass, and other composite materials. They are movable, height-adjustable shelves and clothing rails for exhibiting clothes, footwear, garments, uniforms and other products in retail stores and boutiques.

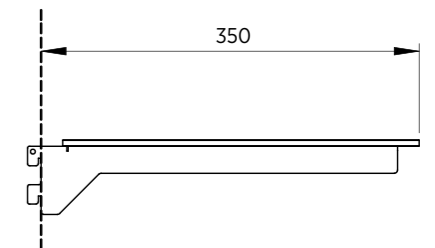
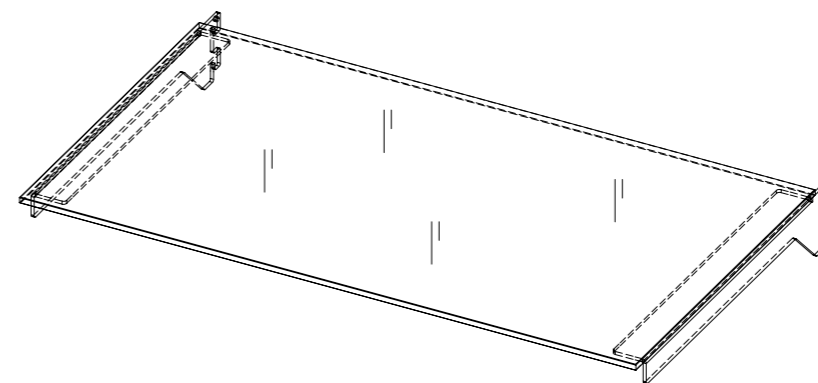

■ GS - 600 (800)

Wood box shelf = WBS

Explore our selection of display elements and find the right combination of shelves, boxes, and rails for your shelving system. We can manufacture custom shelves, rails, and boxes for displaying clothing, garments and uniforms to add to the functionality of your retail space.

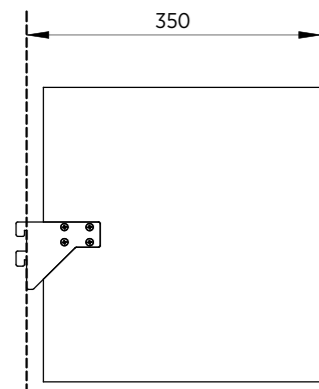
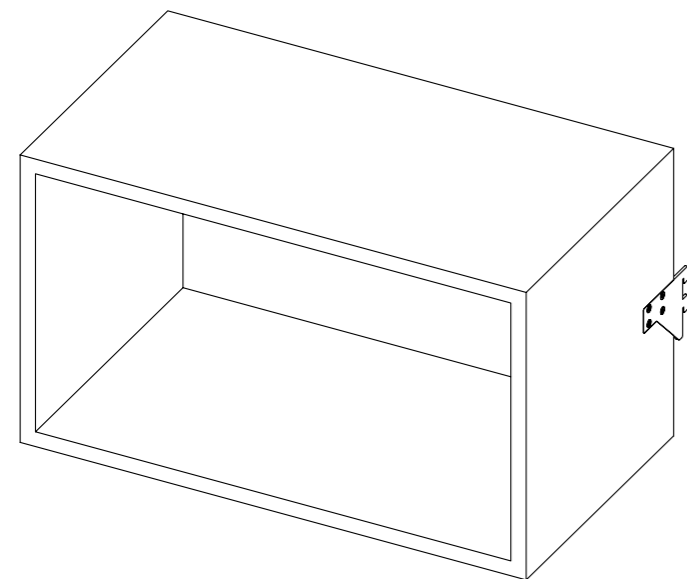

■ WBS - 600 (800)



Hanger Support 1=HS1

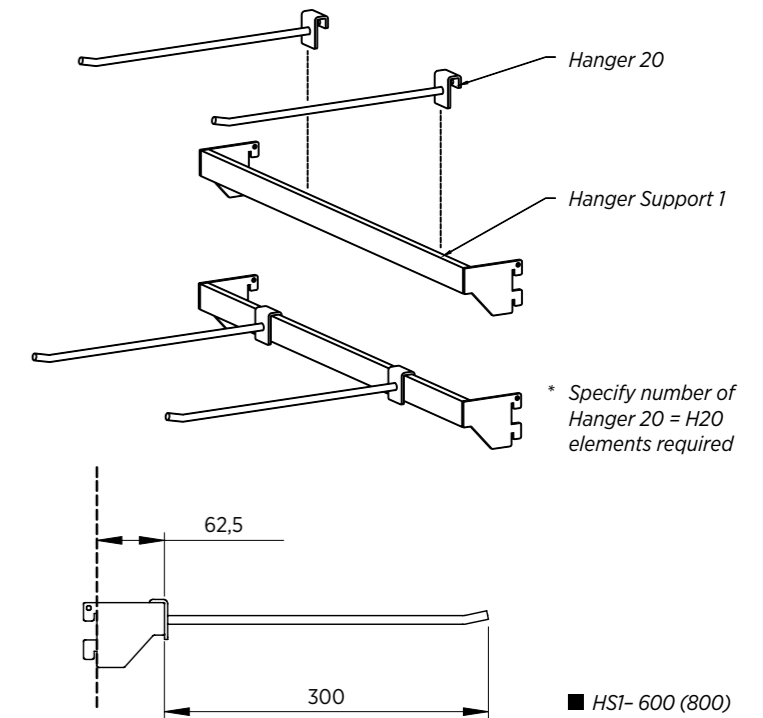

Our products combine fashion and luxury with practicality, adding a modern touch to your clothing store. Delivering shelving systems that are both fashionable and durable, customization can be perfectly combined according to store size and needs, presenting the best results.



Hanger support 2 = HS2

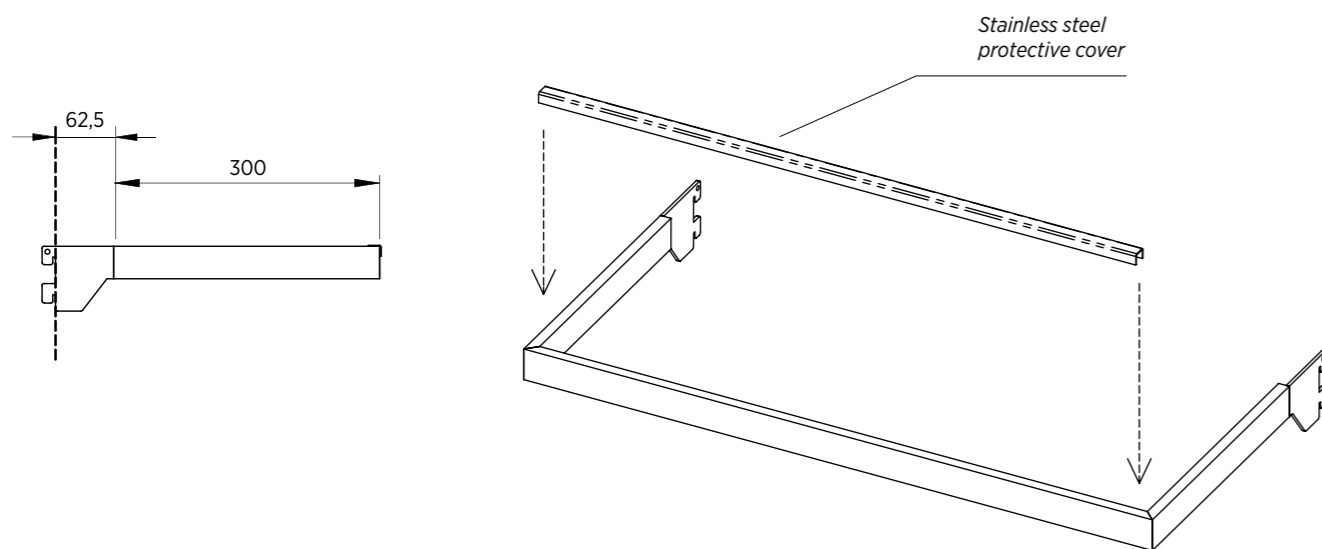

■ HS2 - 600 (800)



These types of display elements are ideal for displaying unique clothing pieces. Made of materials of the highest quality and also budget-friendly!

Hanger support 45 = HS45

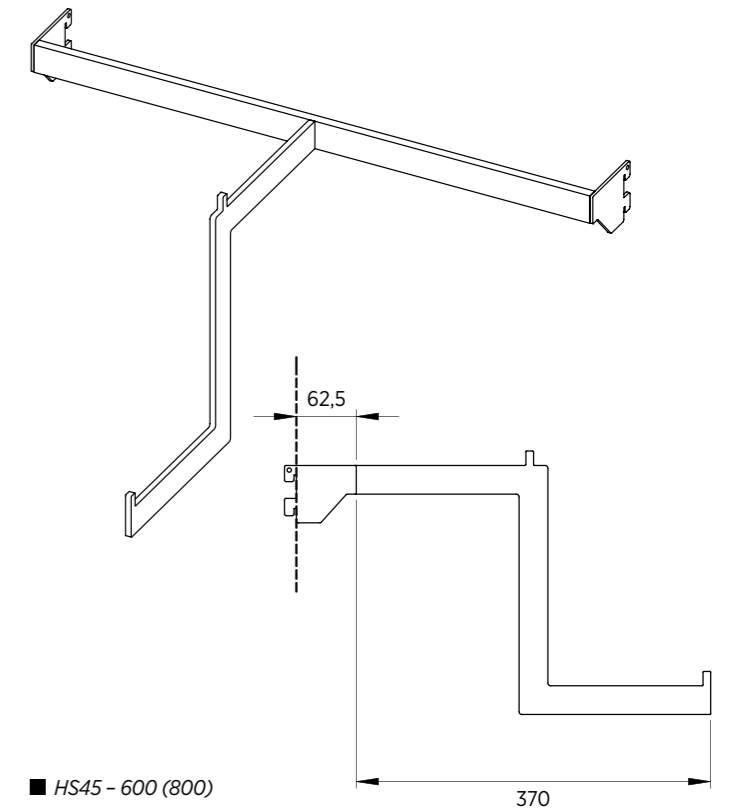

■ HS45 - 600 (800)

Hanger support 46 = HS46

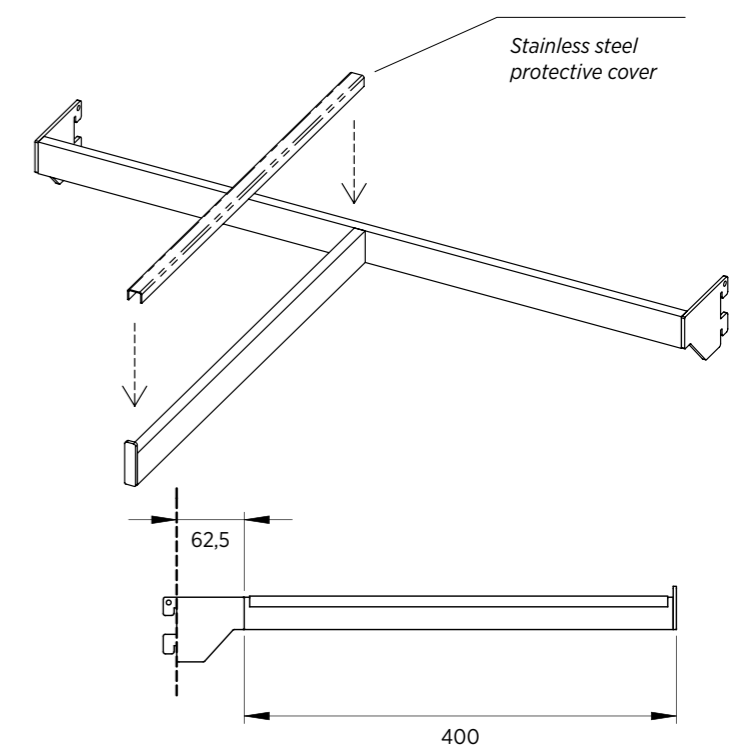

■ HS46 - 600 (800)



Our exhibit elements, rails, shelves, and handles are manufactured to last the longest of periods of time. The dimensions and combinations of shelves are adaptable to any interior.

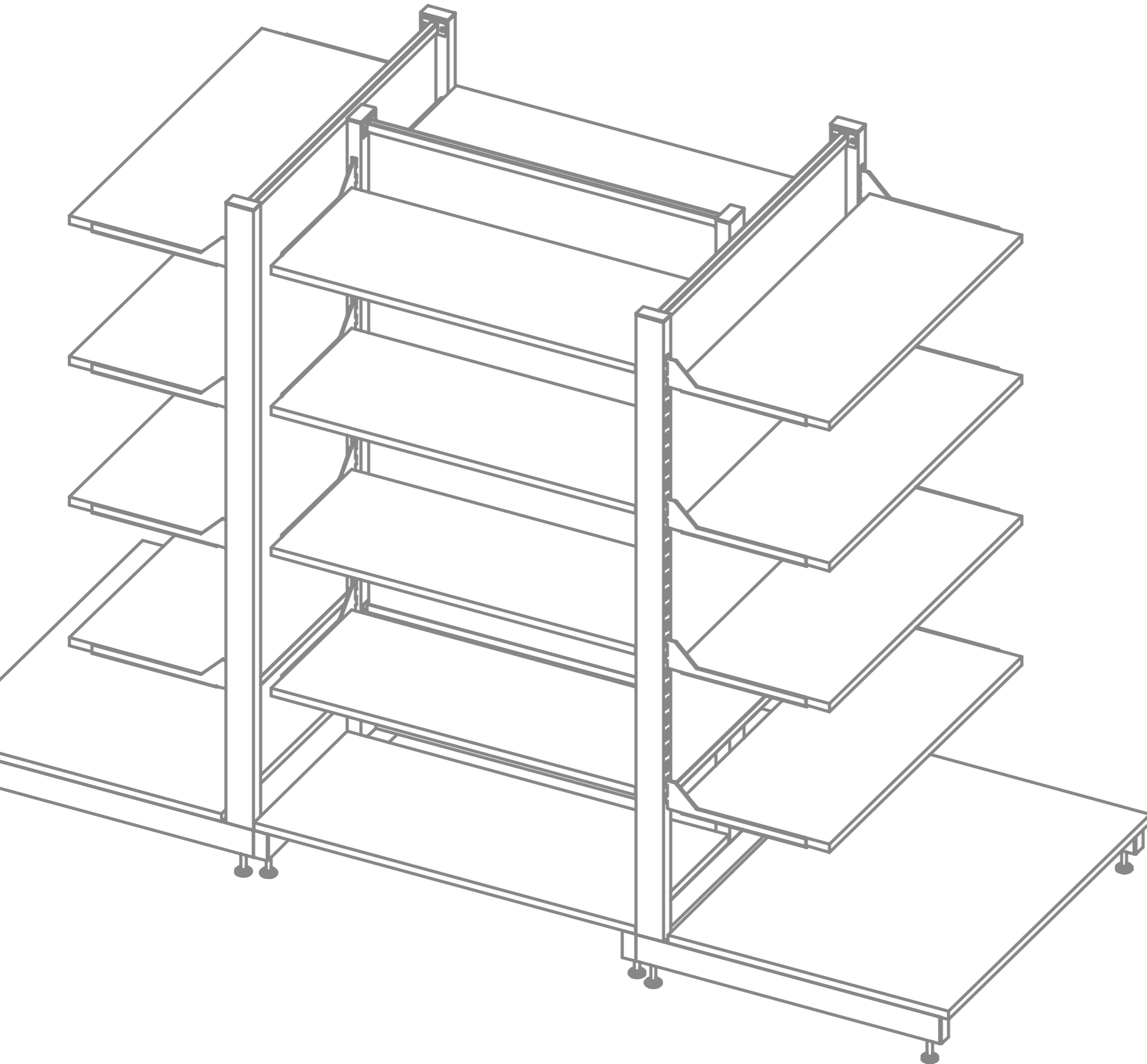

Freestanding retail shelving

Freestanding metal shelving

We deliver an aesthetic, innovative and effective solution for displaying clothing, footwear and accessories which is adaptable to any visual brand identity. The solutions are highly functional, durable and adaptable to any dimension required.

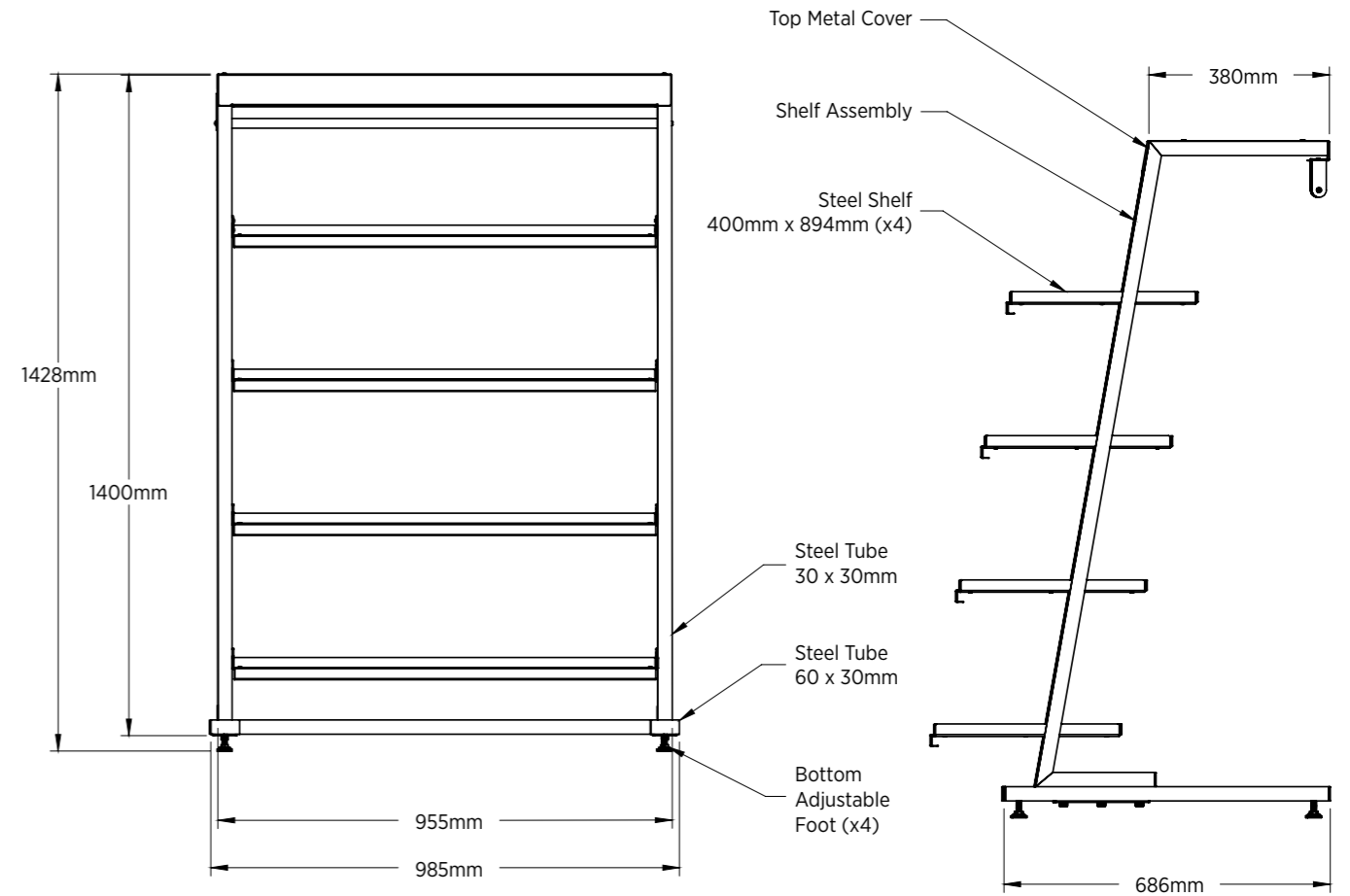
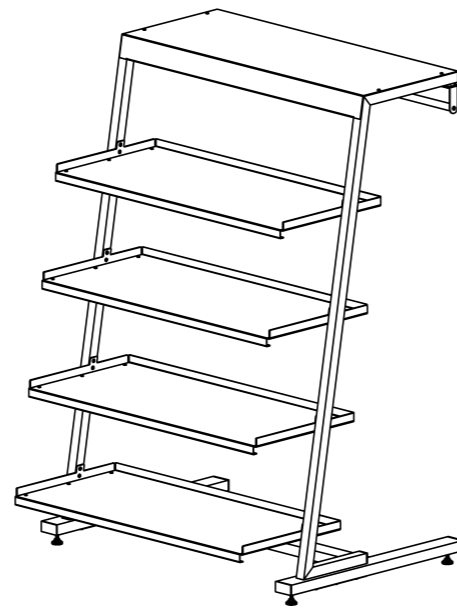

Assembly 64



The combination of metal finishes achieves unique look of the product.

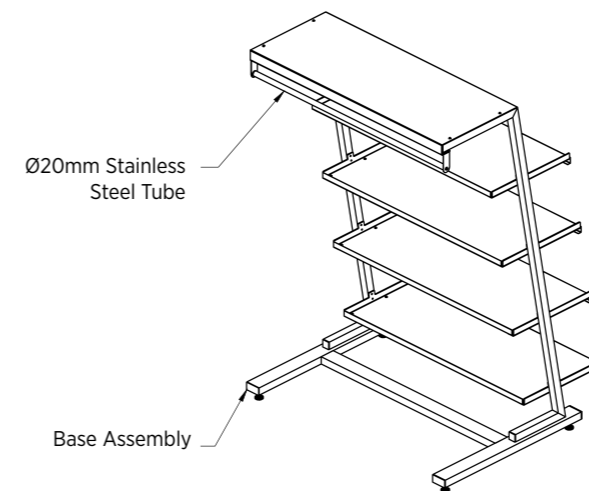

Freestanding wood shelving

We deliver an aesthetic, innovative and effective solution for displaying clothing, footwear and accessories. The solutions are highly functional, durable and adaptable to any dimension required.

Assembly 72



Our products combine fashion and luxury with practicality, adding a modern touch to your clothing store. Delivering shelving that are both fashionable and durable. Customization can be done according to store size and needs, presenting the best result.





We manufacture high quality metal furnishings and elements with options of combinations with wood, chipboard, glass, and other composite materials.

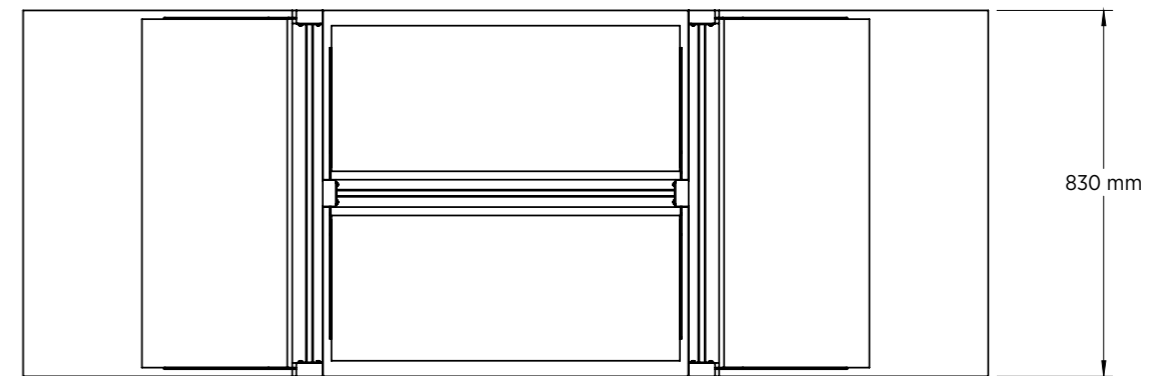
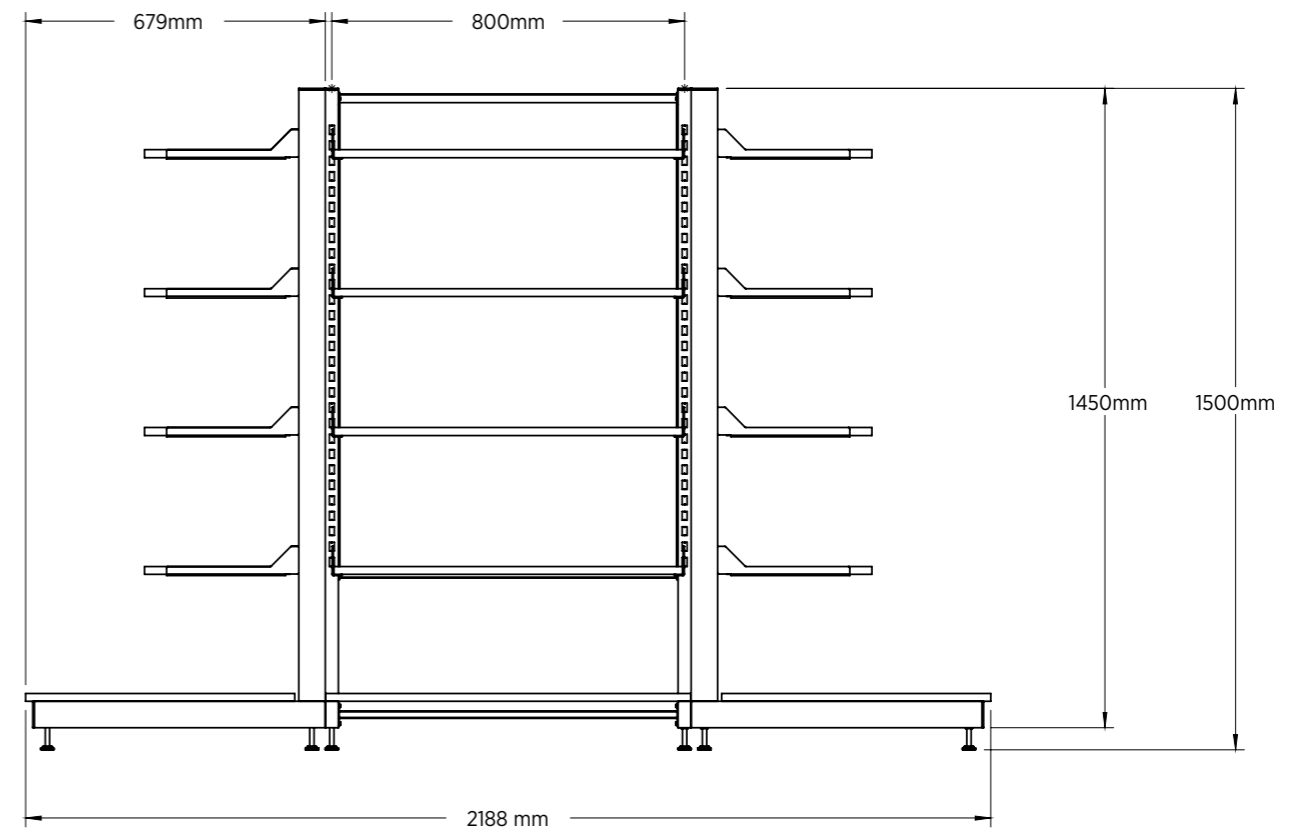

Miscellaneous shelving

For exhibiting miscellaneous products, we deliver modern shelving solutions of the highest quality and aesthetic. The solution is highly functional and adaptable to any dimension required.



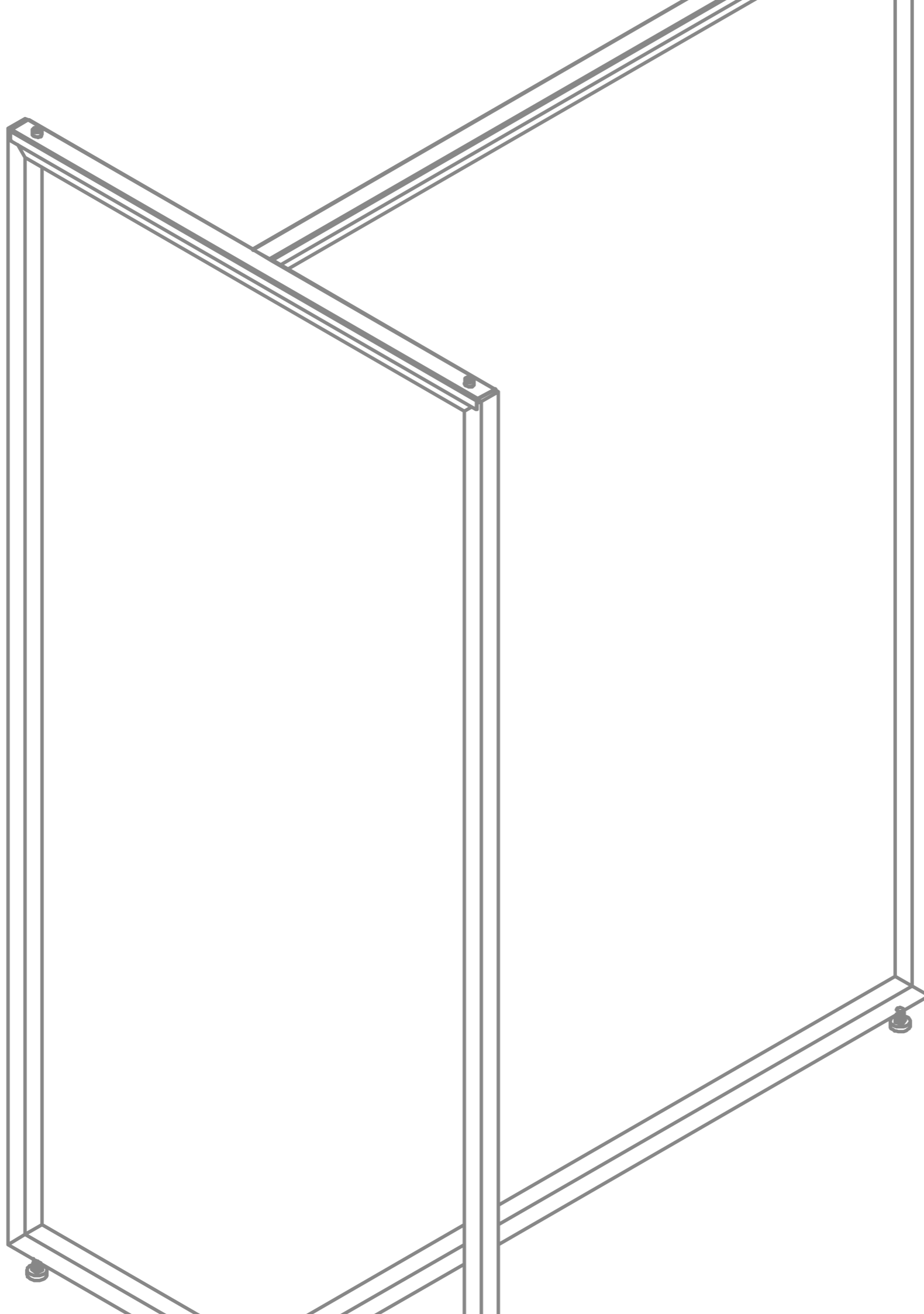

Retail Display **Stands**

Display stands for clothing

Delivering display stands that are both fashionable, durable and adding a modern touch to your clothing store. Customization can be done according to store size and needs, presenting the best result.



For exhibiting textile pieces in retail stores and boutiques, we offer high quality stands for displaying clothing, uniforms and garment with adaptable dimensions.

Assembly 63 - 700

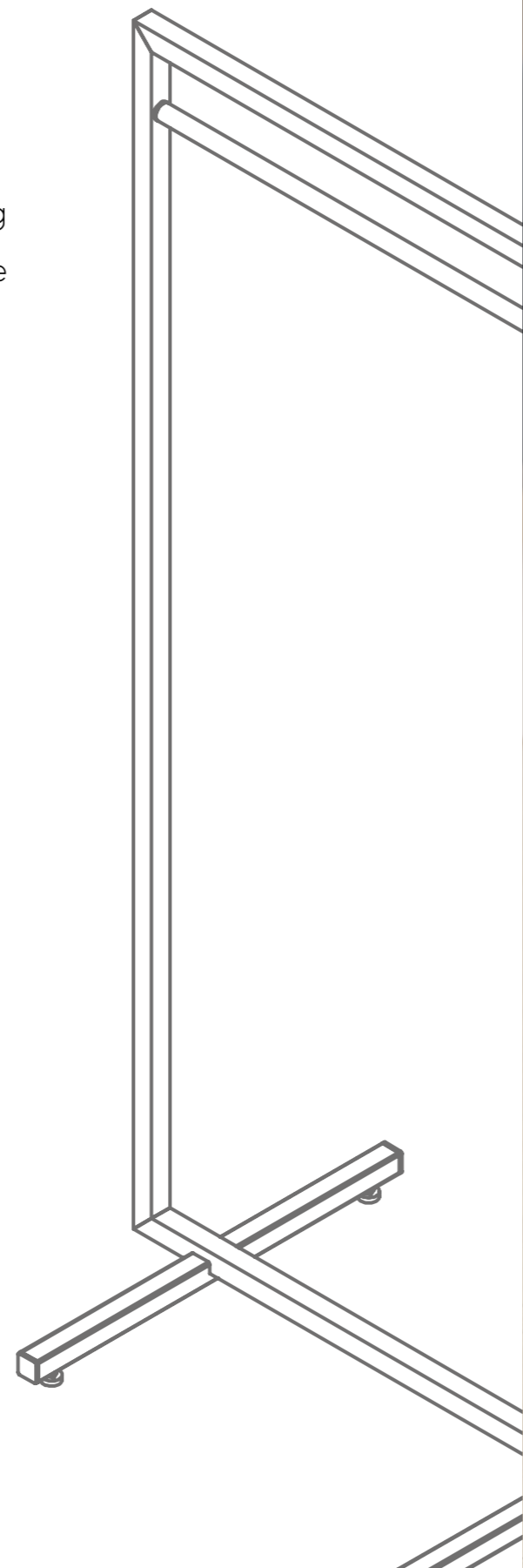
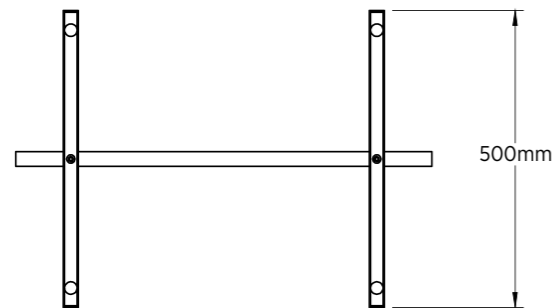
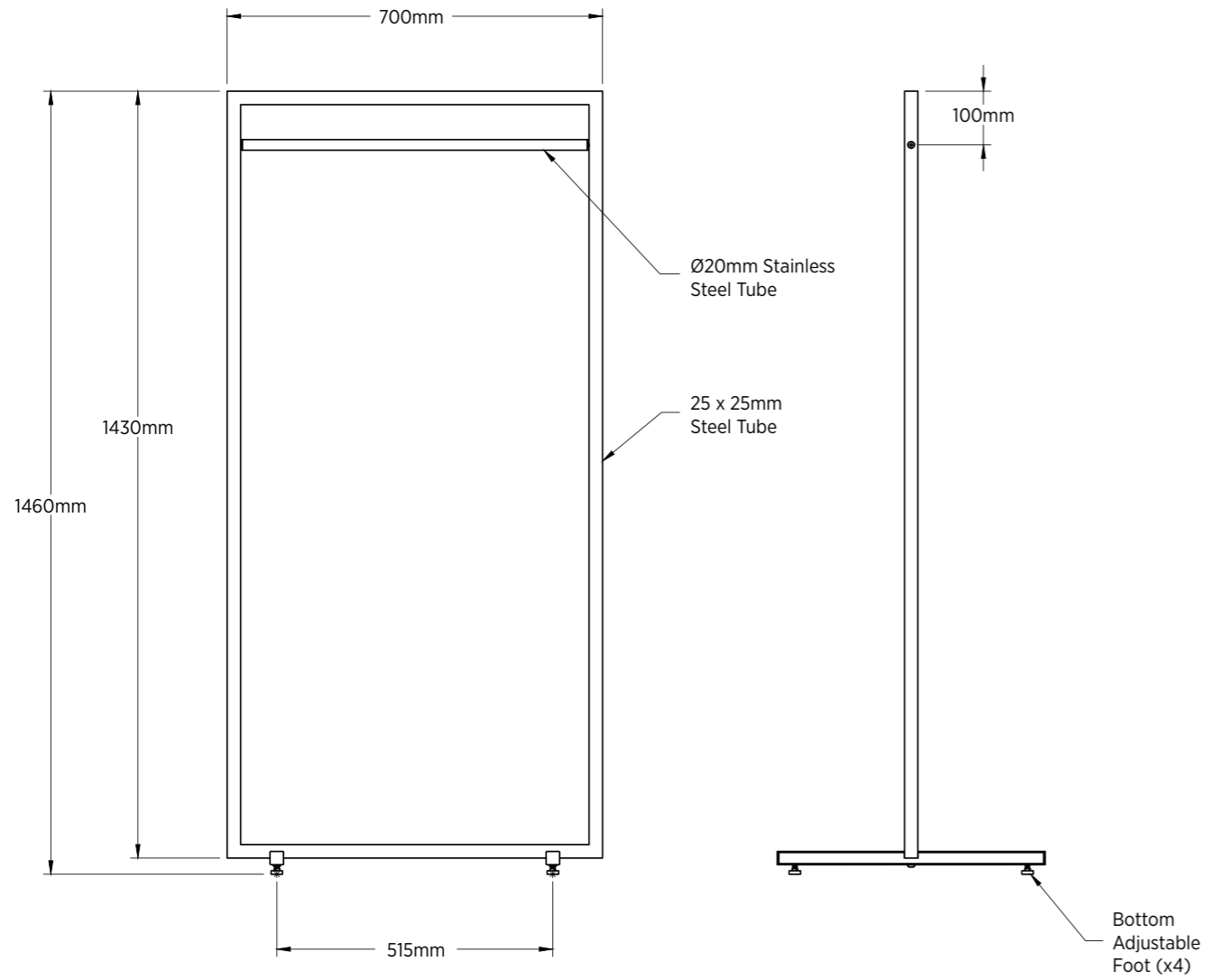
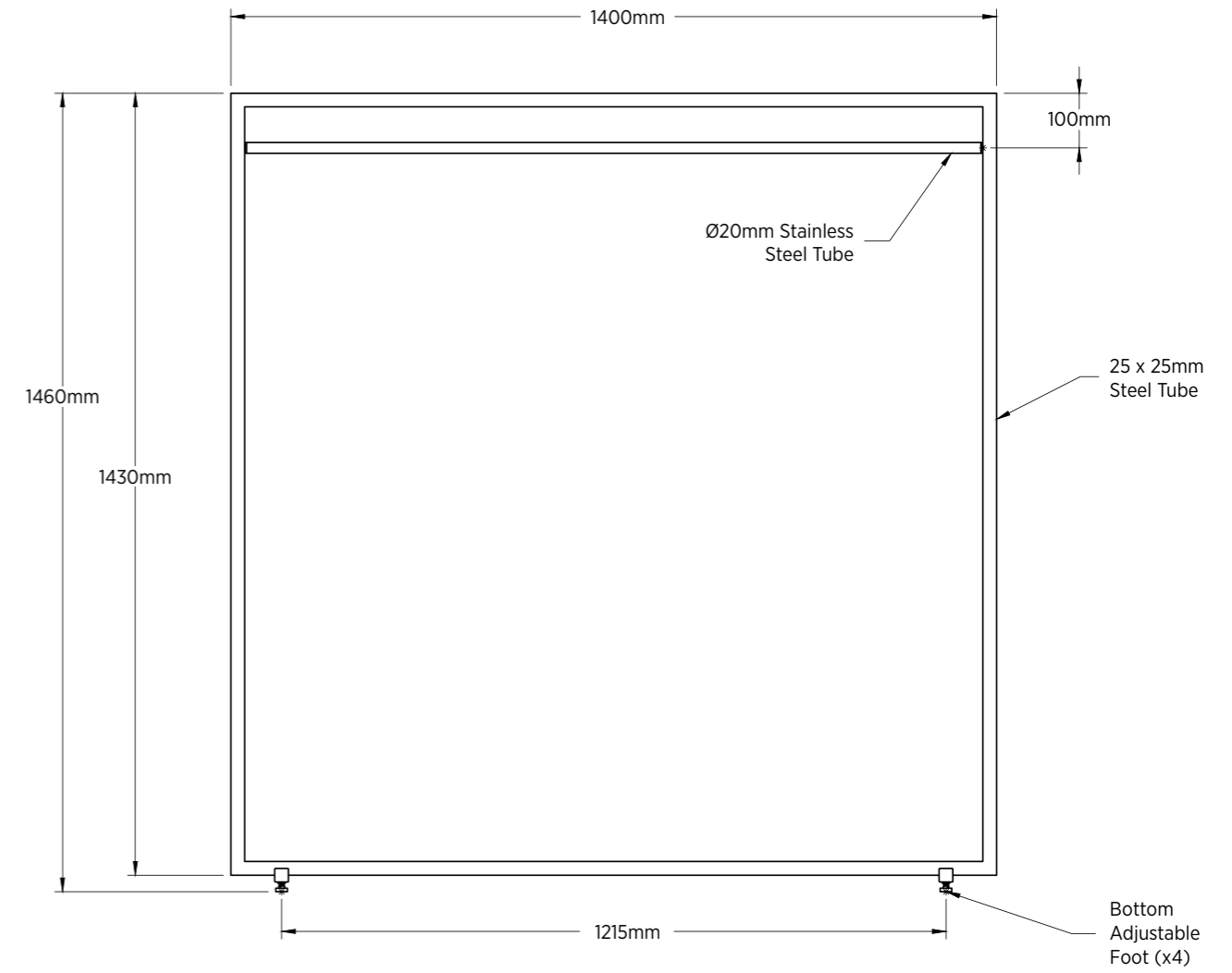

Exhibit stands are offered in standard lengths of 700mm and 1400mm. We can also manufacture them in dimensions as per client's request.



■ Assembly 63 - 700



■ Assembly 63 - 1400

Assembly 63 - 1400



Assembly 65 - 700 x 700



Our exhibit stands ensure that your space will be highly aesthetic, stylishly recognizable, functional and perfectly tailored to the needs of your business. We also offer custom exhibit stands adaptable to any visual brand identity.

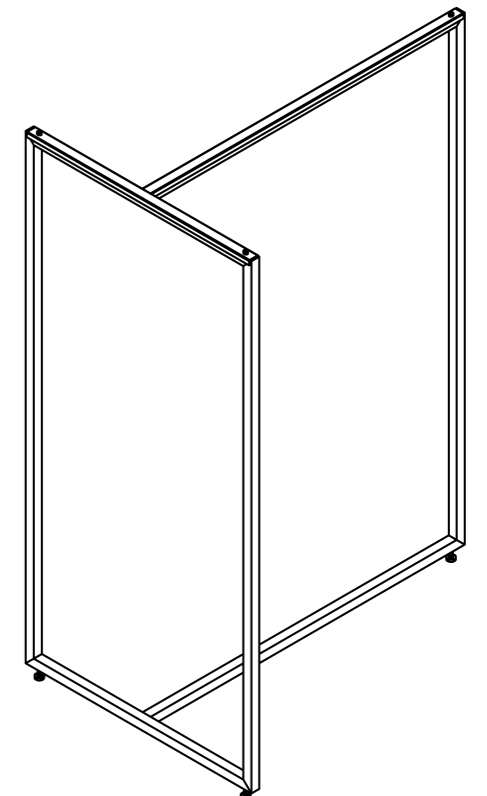
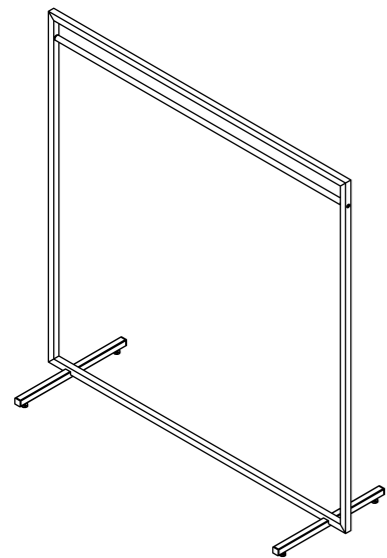
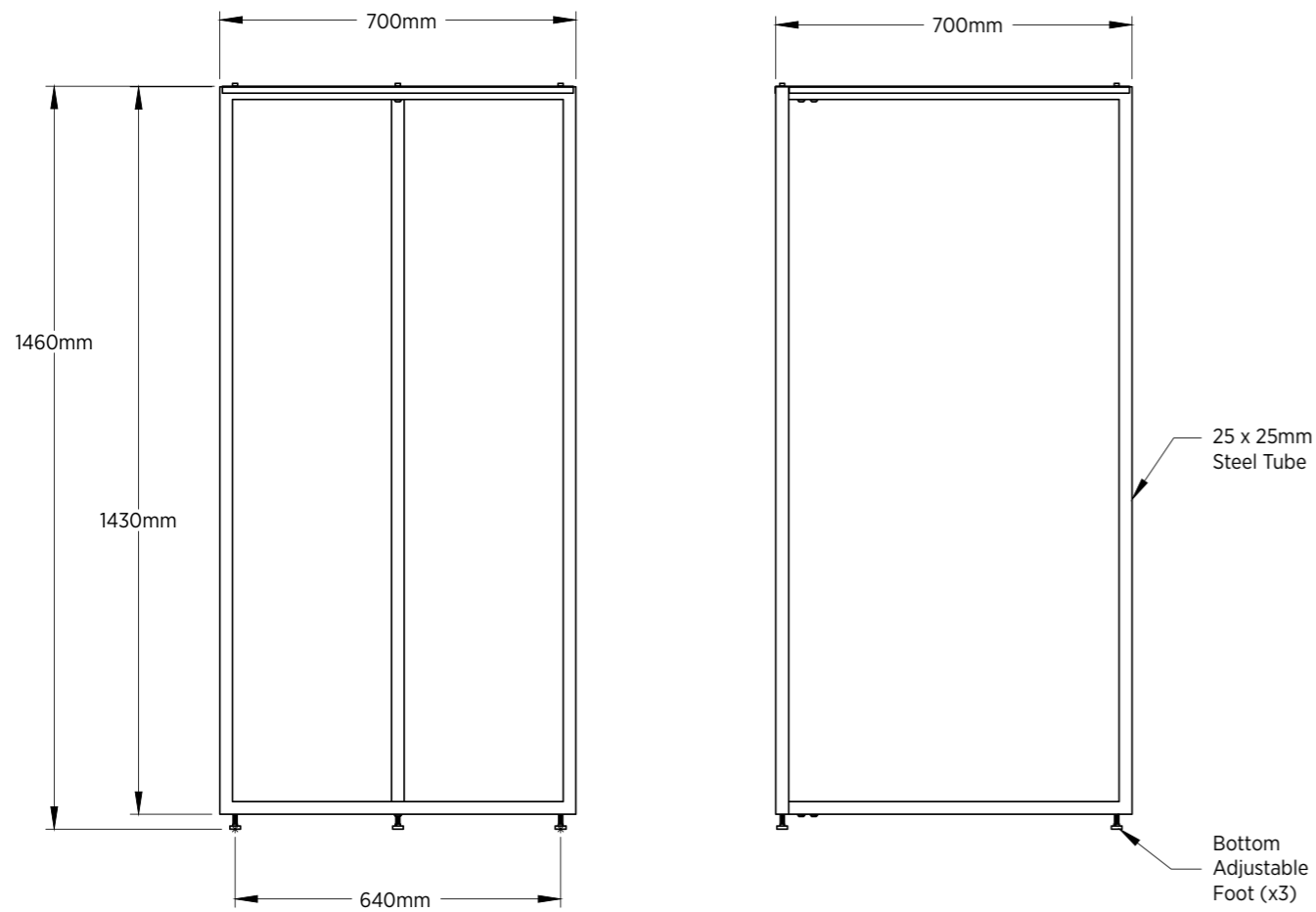
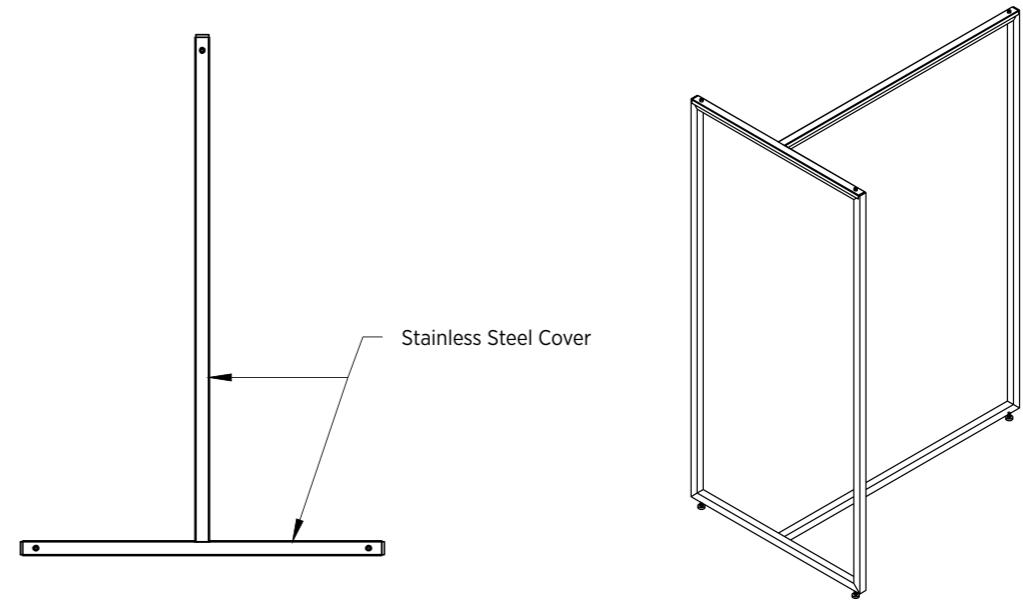
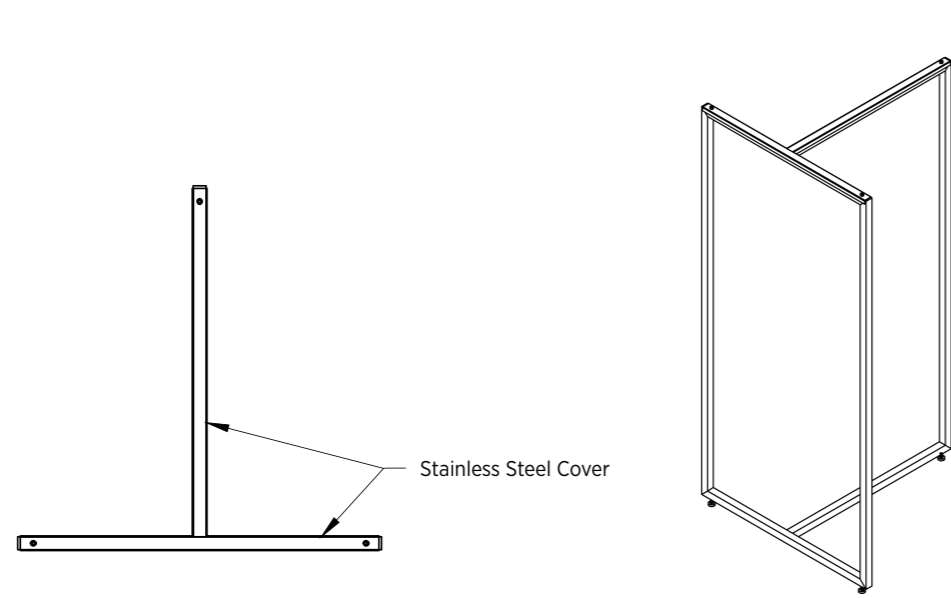
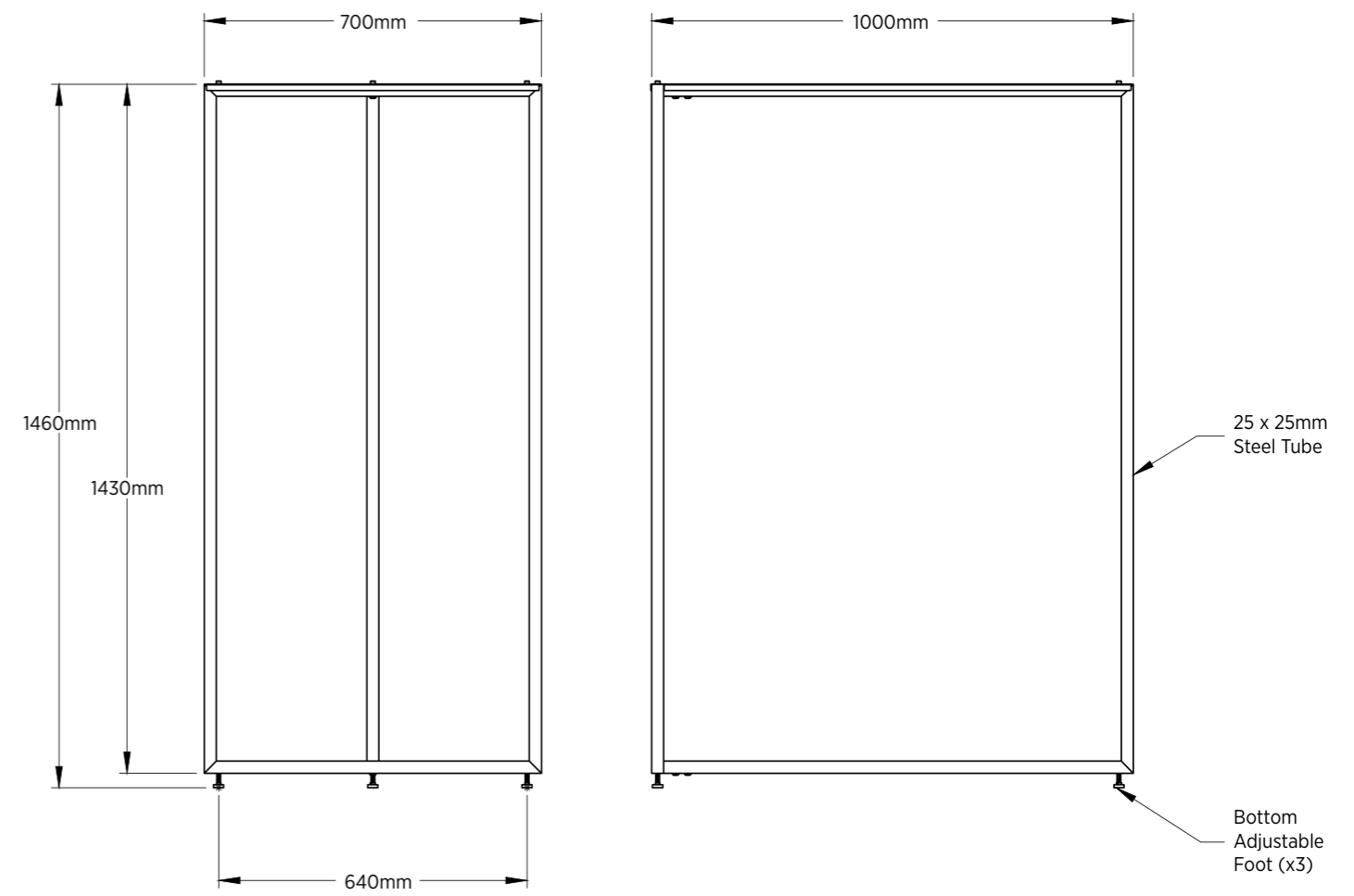

Exhibit stands are offered in standard lengths of 700mm and 1000mm. We can also manufacture them in dimensions per client's request.



■ Assembly 65 - 700 x 700



■ Assembly 65 - 700 x 1000

Assembly 66



We have the option of covering the top part of the exhibit stand with a stainless steel sheet metal cover or stainless steel solid rod - per clients wishes.

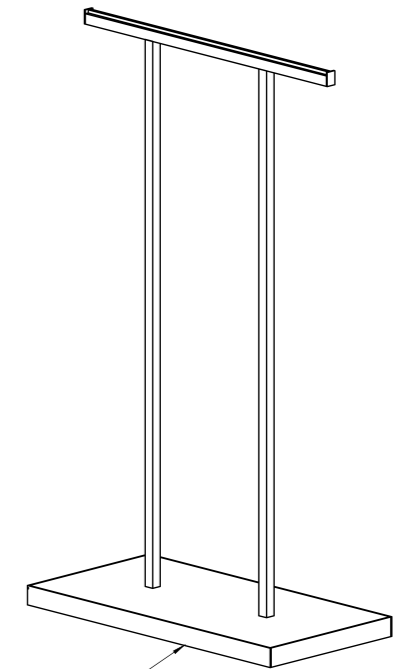
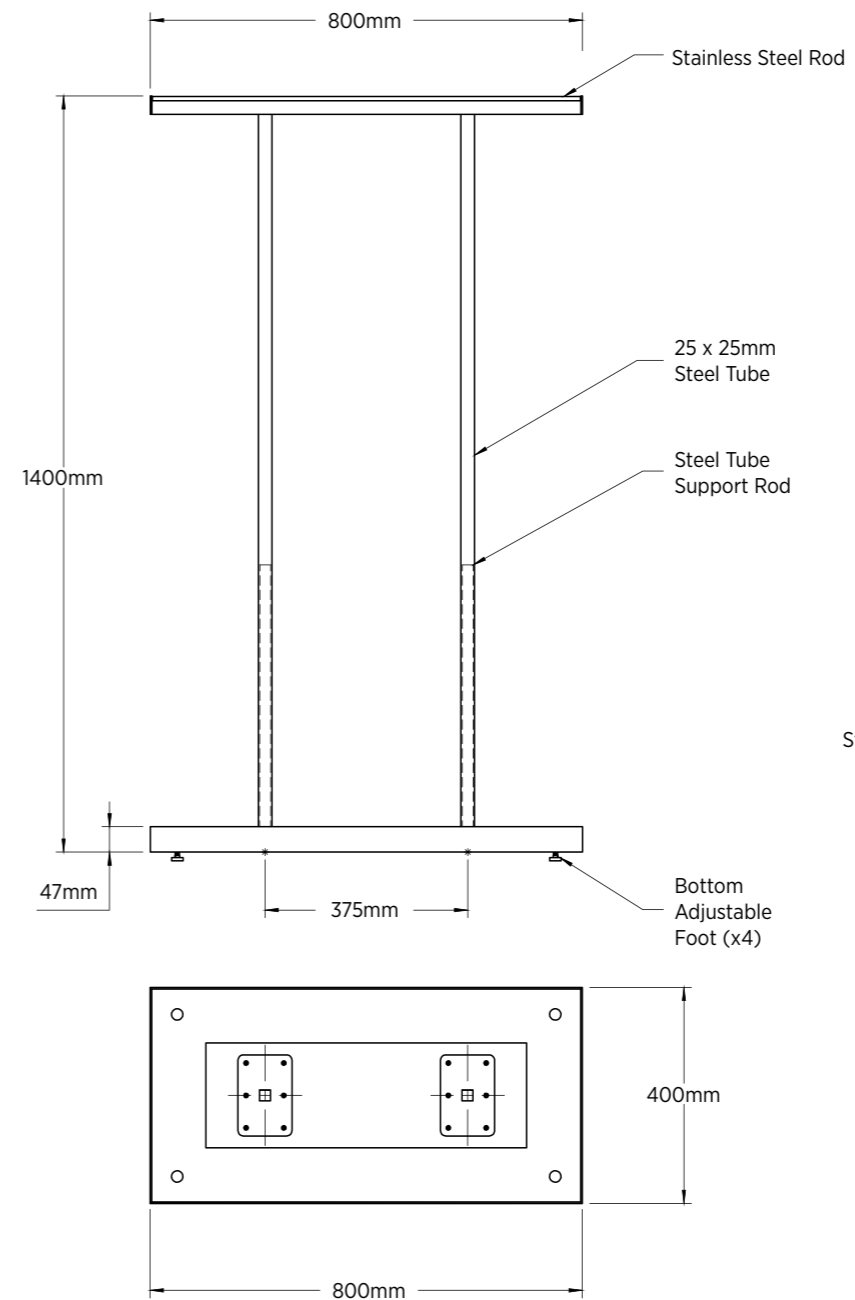

Metal-Framed Wooden Base

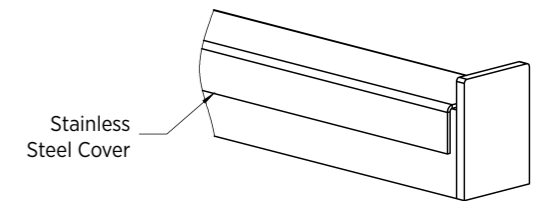

■ Option 1: Stainless steel cover

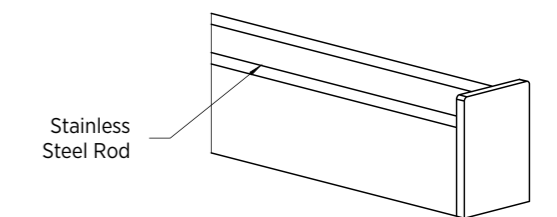

■ Option 2: Stainless steel rod

Custom **Solutions**



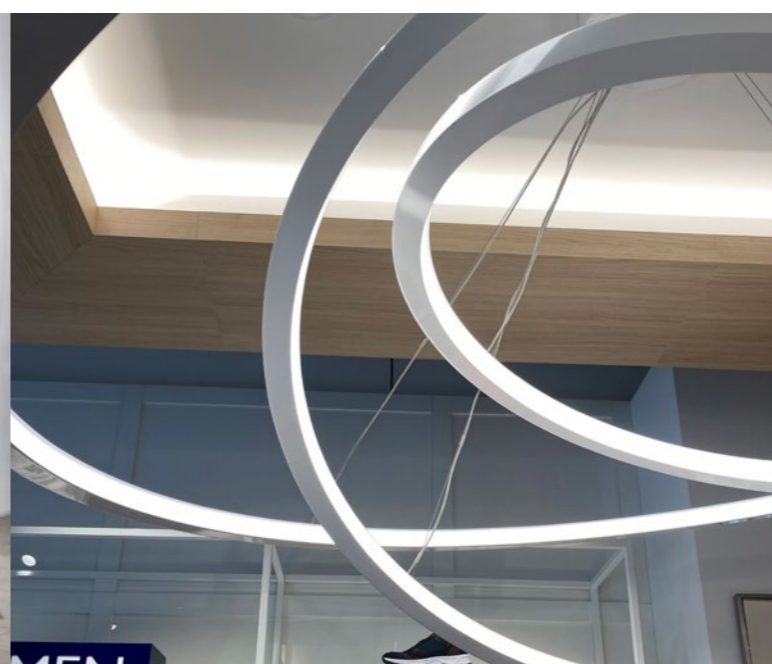
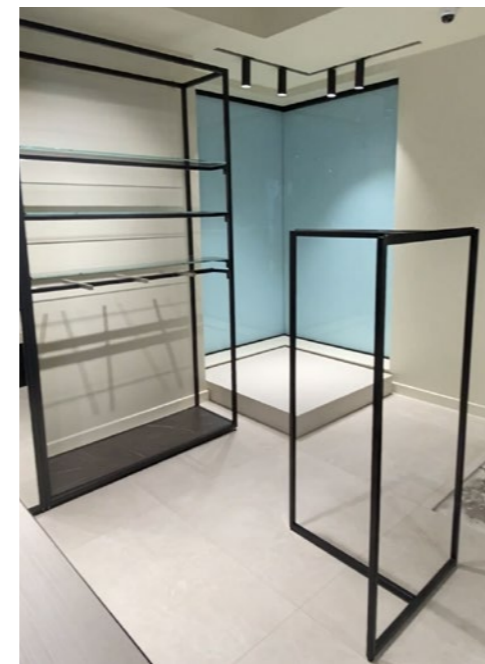



Al-Lux d.o.o.
Put za Aluminij bb,
88000 Mostar, Bosna i Hercegovina
E-mail: info@al-lux.com
Web: www.al-lux.com

EU MARKET

Al-Lux d.o.o.
Bani 73,
10010 Zagreb, Croatia
E-mail: info@al-lux.com
Web: www.al-lux.com



Al-Lux d.o.o.
Put za Aluminij bb,
88000 Mostar, Bosna i Hercegovina
E-mail: info@al-lux.com
Web: www.al-lux.com

EU MARKET

Al-Lux d.o.o.
Bani 73, 10010 Zagreb, Croatia
E-mail: info@al-lux.com
Web: www.al-lux.com

