

SWS - 2950 - C600 - WS - 800 - L2 - 1

1

2

3

4

5

6

7

- 1 SWS : Shelving Wall-mount System
- 2 2600 - 2950 : Vertical rail height (in millimeters measured from floor).
2950mm vertical rail supplied as a standard. Heights
from 2600 to 2950mm available.
- 3 C600 - C900 : Option with down light console (length in millimeters).
600mm console supplied as a standard. Lengths from
600 to 900mm available.
X : Option without down light console.
- 4 WS : Option with wooden sides.
X : Option without wooden sides.
- 5 600 or 800 : Vertical rails axial distance in millimeters.
- 6 Module type:
S _ : Single module...
L _ : Left module...
M _ : Middle module...
R _ : Right module...
_ 2 : ...with two vertical rails
_ 3 : ...with three vertical rails
- 7 Surface finish options:
1 : Raw/unfinished
2 : Black (RAL 9005 matte)
3 : White (RAL 9010 matte)
4 : Anthracite (RAL 7016 matte)

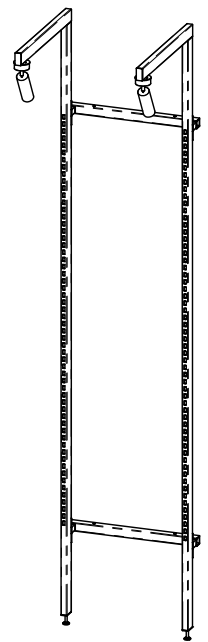
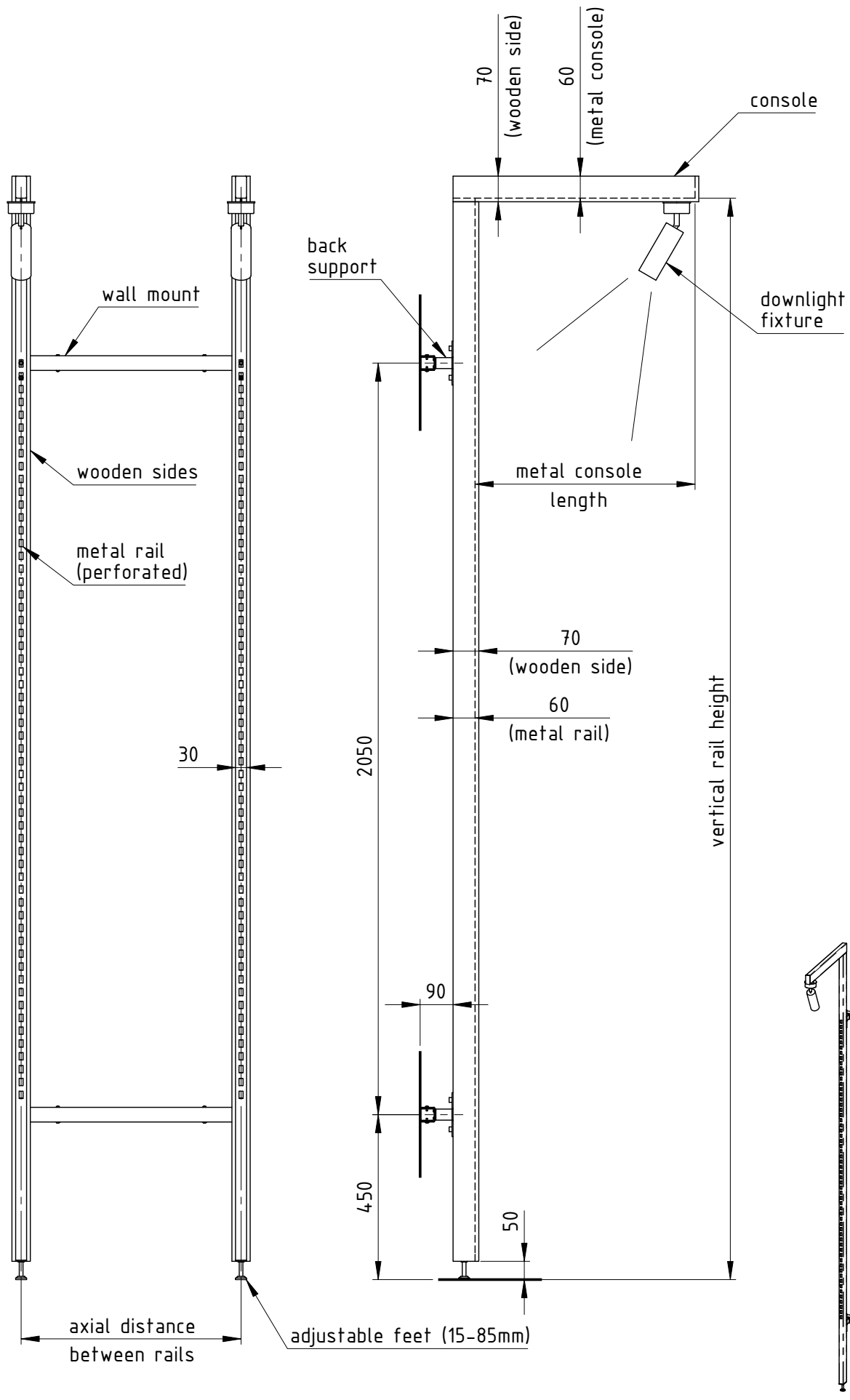

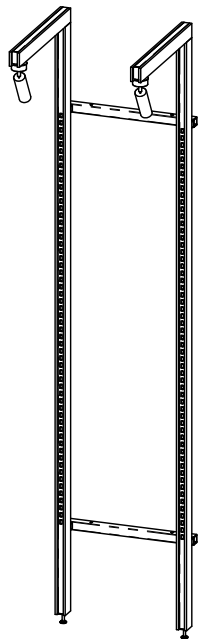

SINGLE
Two rails

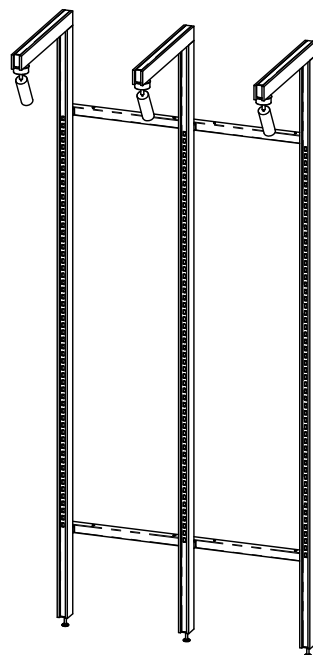

SINGLE
Three rails

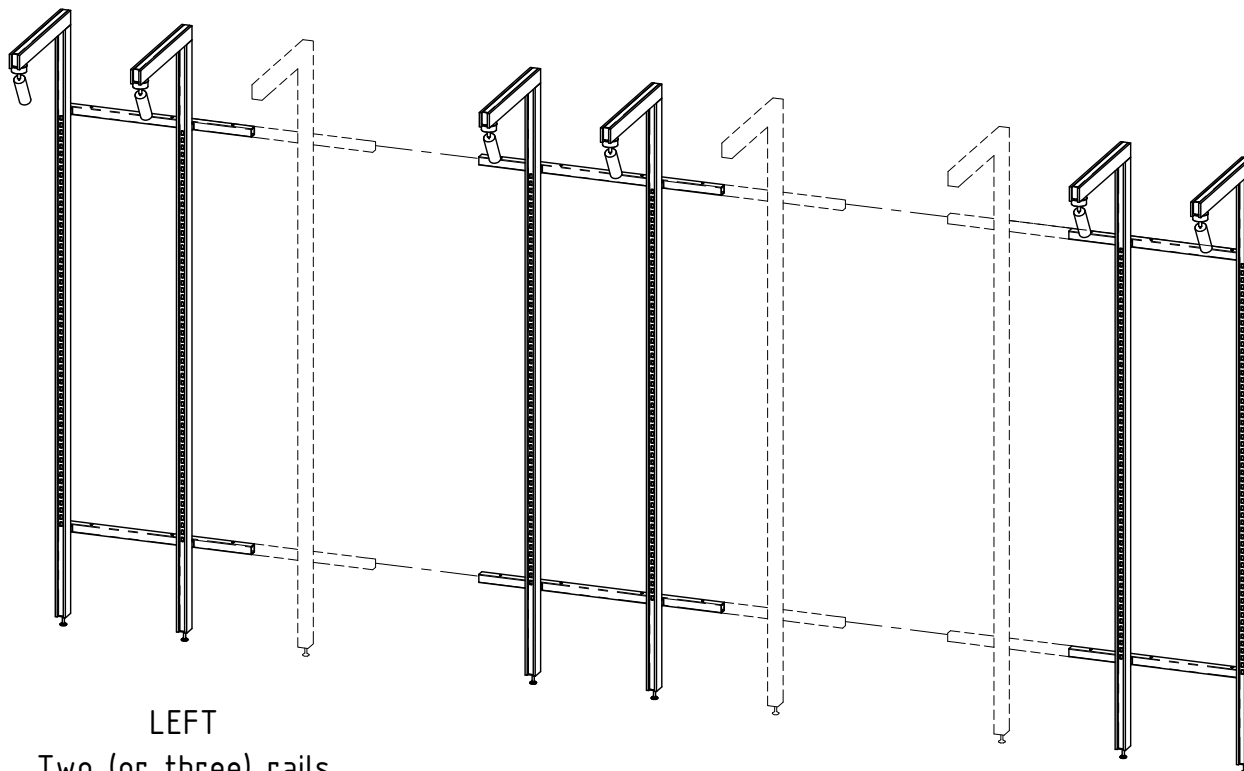

LEFT
Two (or three) rails

MIDDLE
Two (or three) rails

RIGHT
Two (or three) rails

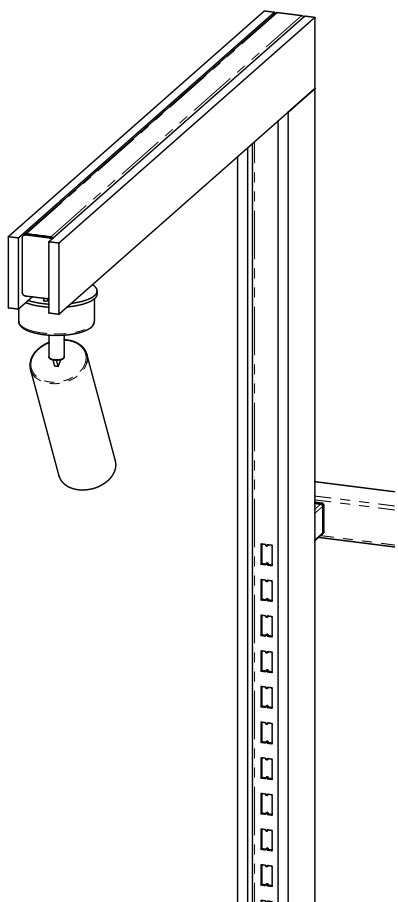

With wooden sides

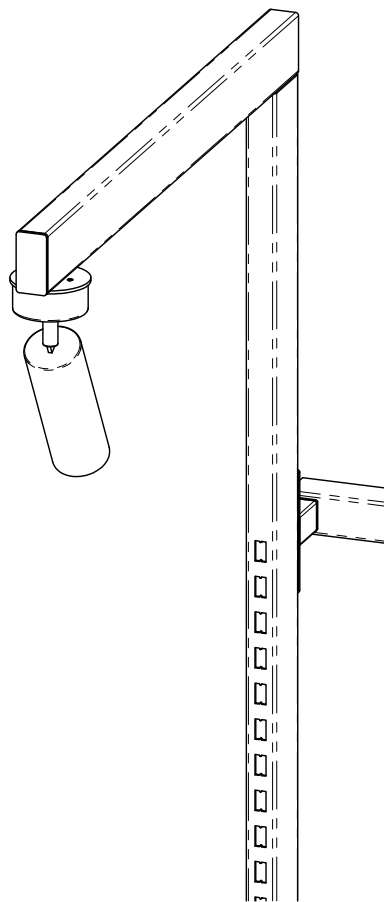

Without wooden sides

Wood material – as per client selection.

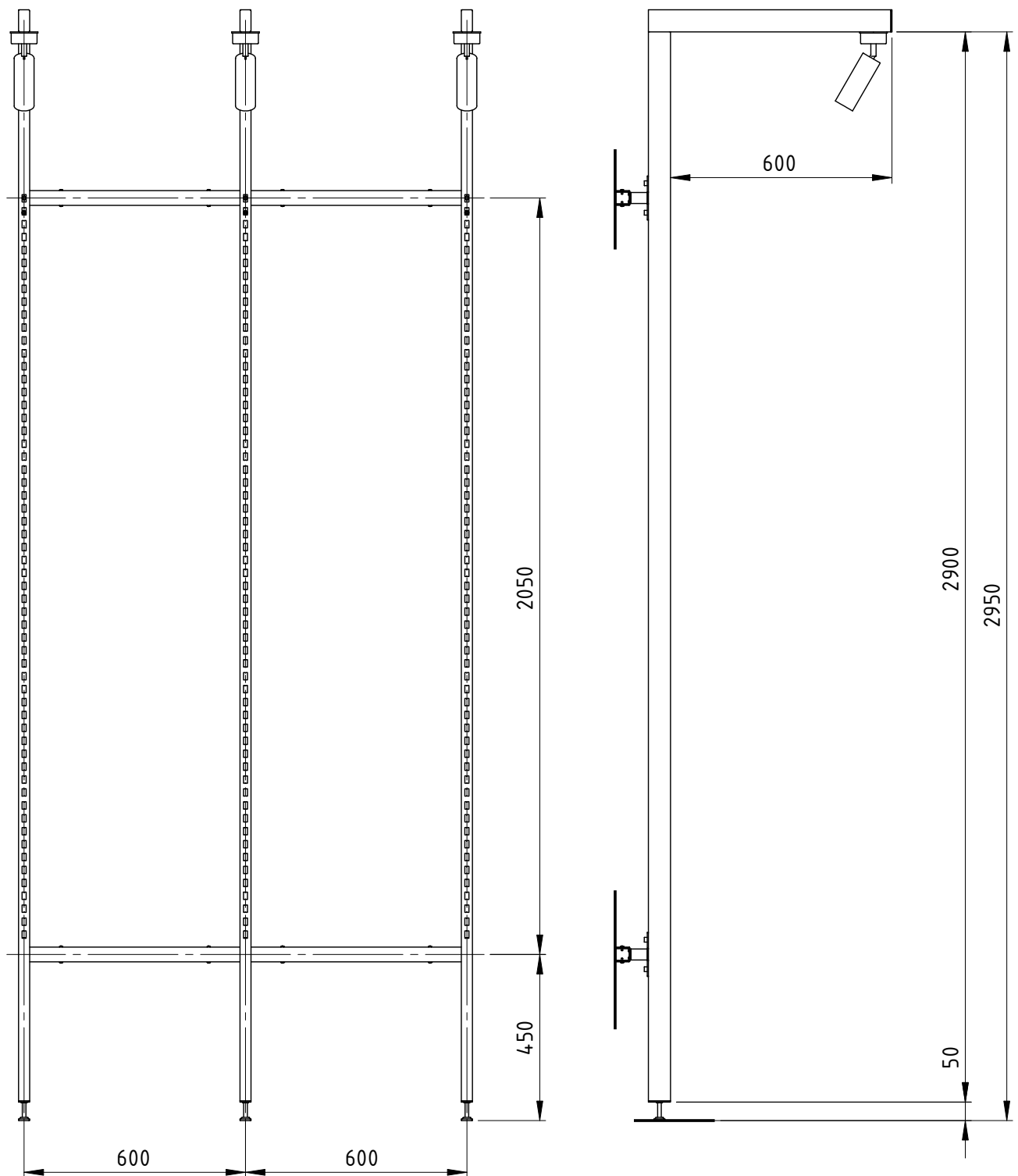

- SWS** : Shelving Wall System
2950 : Vertical rail height 2950mm
C600 : With down light console, length 600mm
X : Without wooden sides
600 : Vertical rails axial distance 600mm
S3 : Single module with three vertical rails
2 : Black surface finish (RAL 9005 matte)

EXAMPLE 1

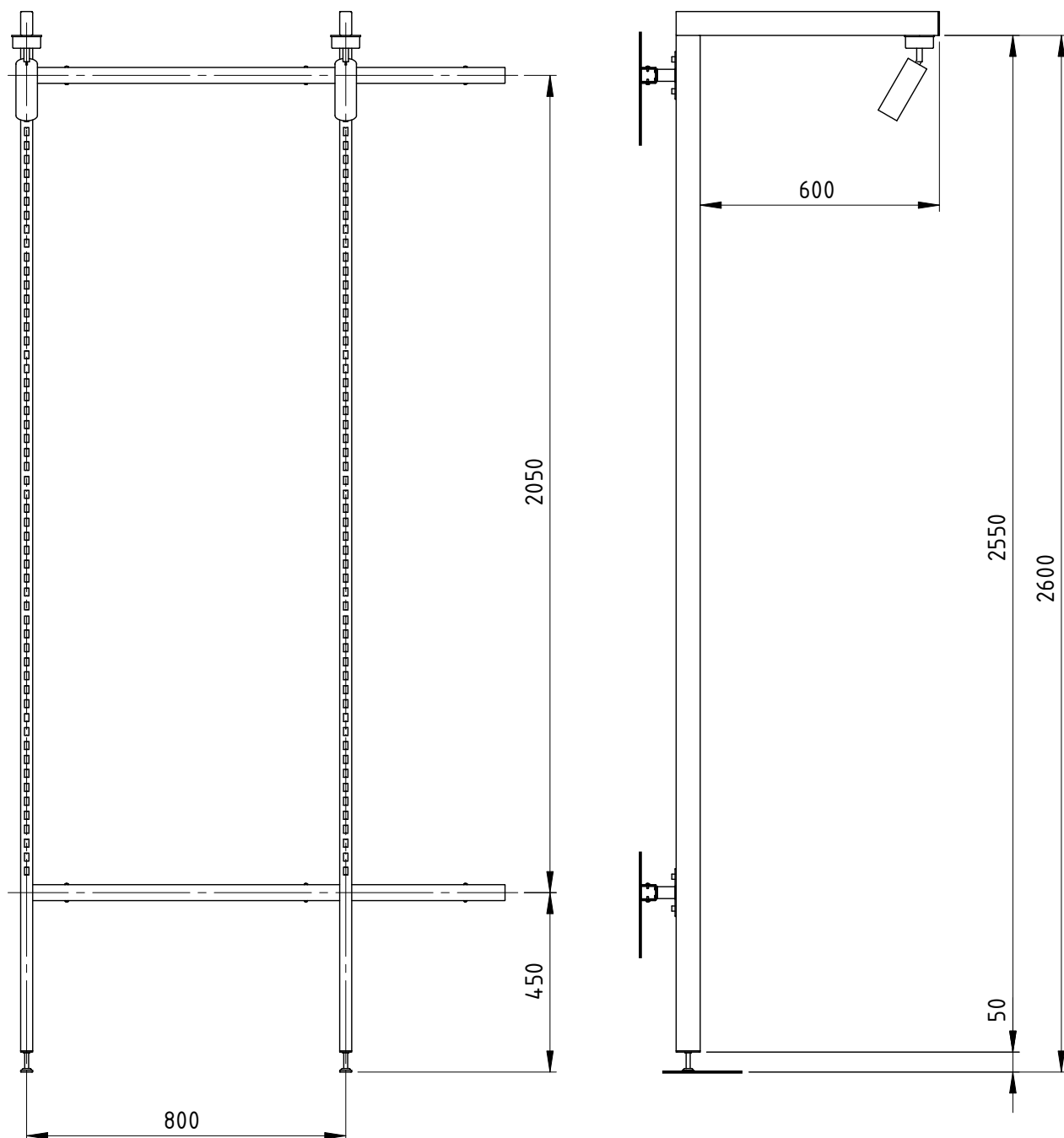

- SWS** : Shelving Wall System
2600 : Vertical rail height 2600mm
C600 : With down light console, length 600mm
X : Without wooden sides
800 : Vertical rails axial distance 800mm
L2 : Left module with two vertical rails
1 : Raw/unfinished surface

EXAMPLE 2

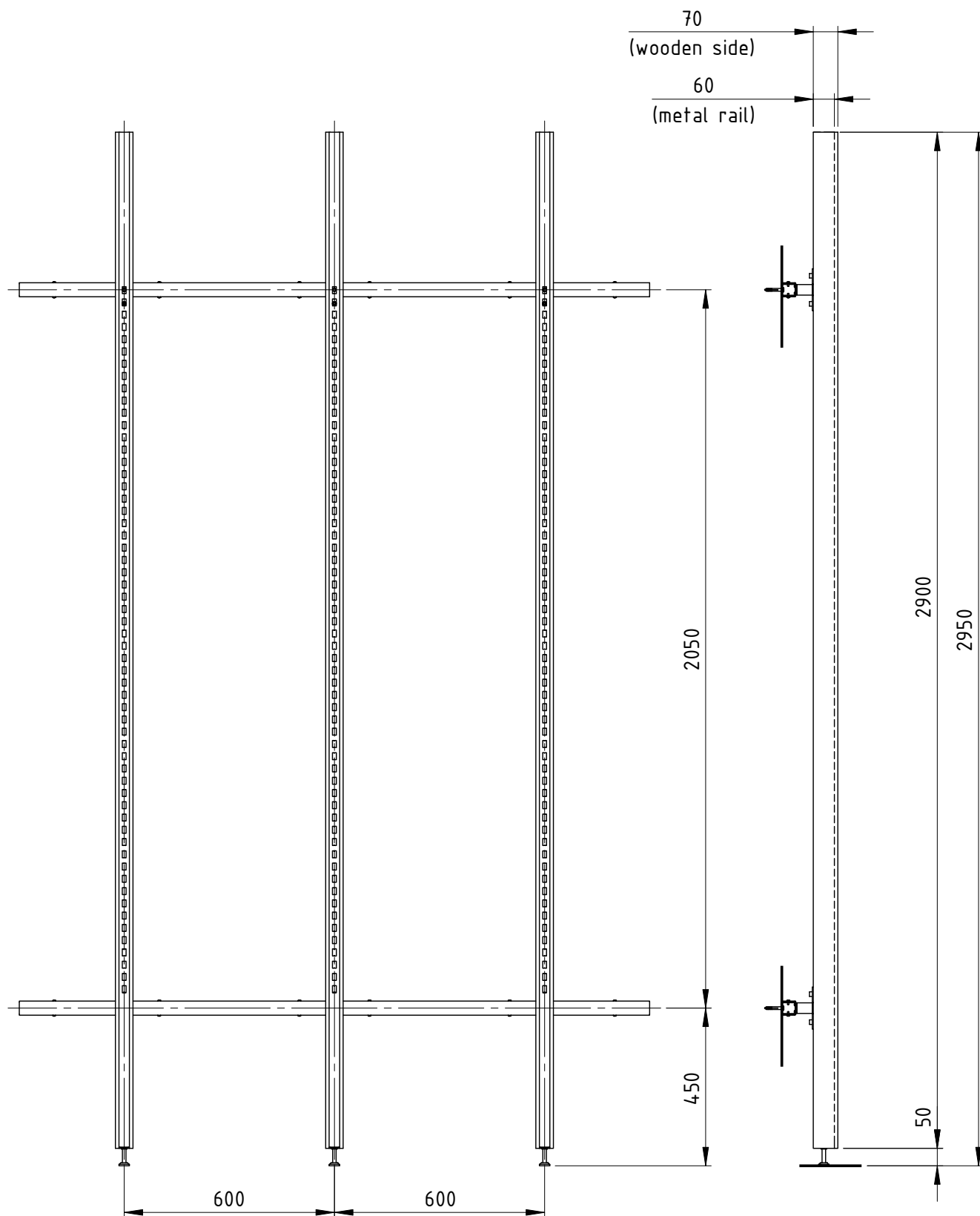

- SWS** : Shelving Wall System
2950 : Vertical rail height 2950mm
X : Without downlight console
WS : With wooden sides
600 : Vertical rails axial distance 600mm
M3 : Middle module with three vertical rails
3 : White surface finish (RAL 9010 matte)

EXAMPLE 3

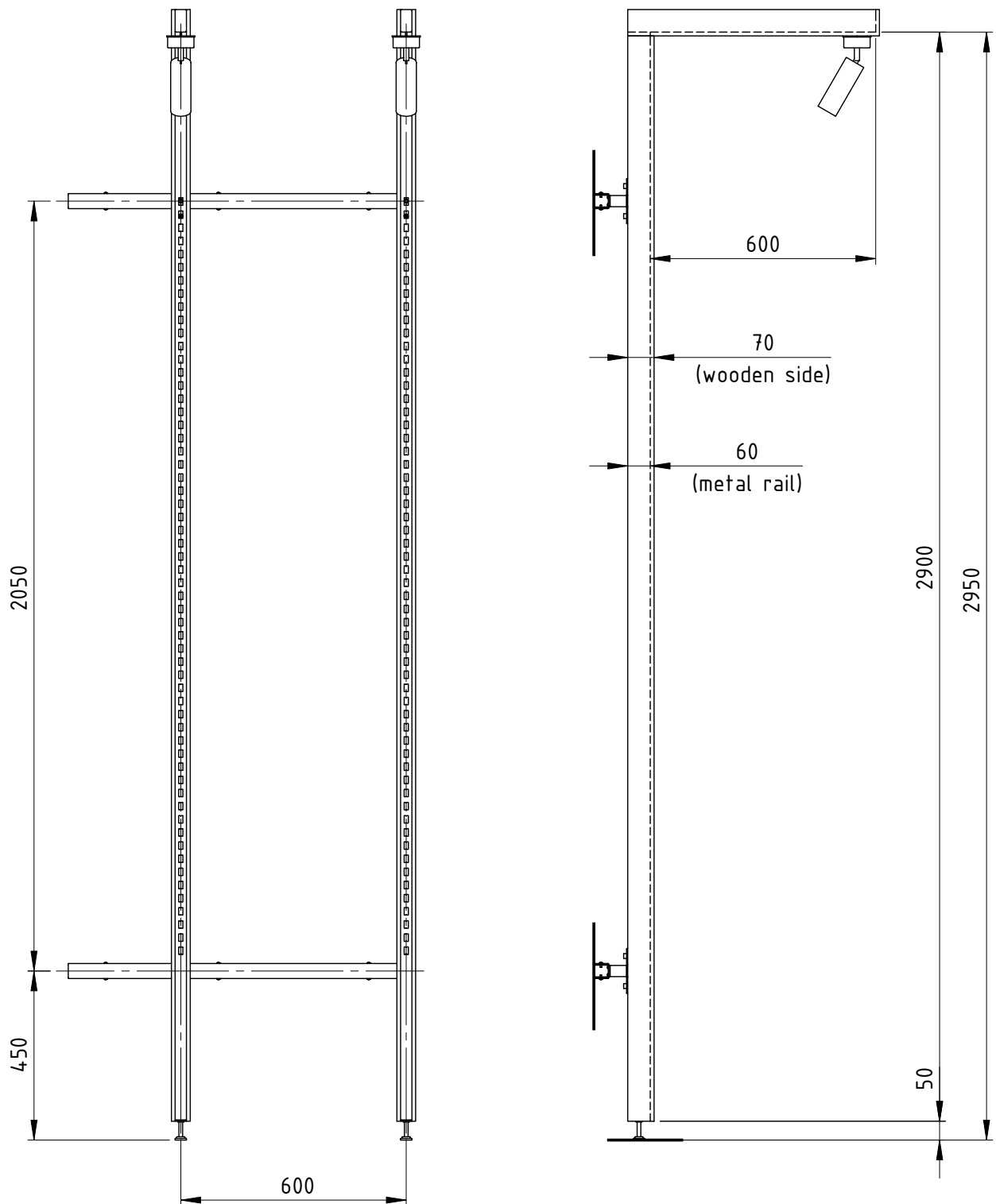

- SWS : Shelving Wall System
- 2950 : Vertical rail height 2950mm
- C600 : With down light console, length 600mm
- WS : With wooden sides
- 600 : Vertical rails axial distance 600mm
- R2 : Right module with two vertical rails
- 3 : White surface finish (RAL 9010 matte)

EXAMPLE 4

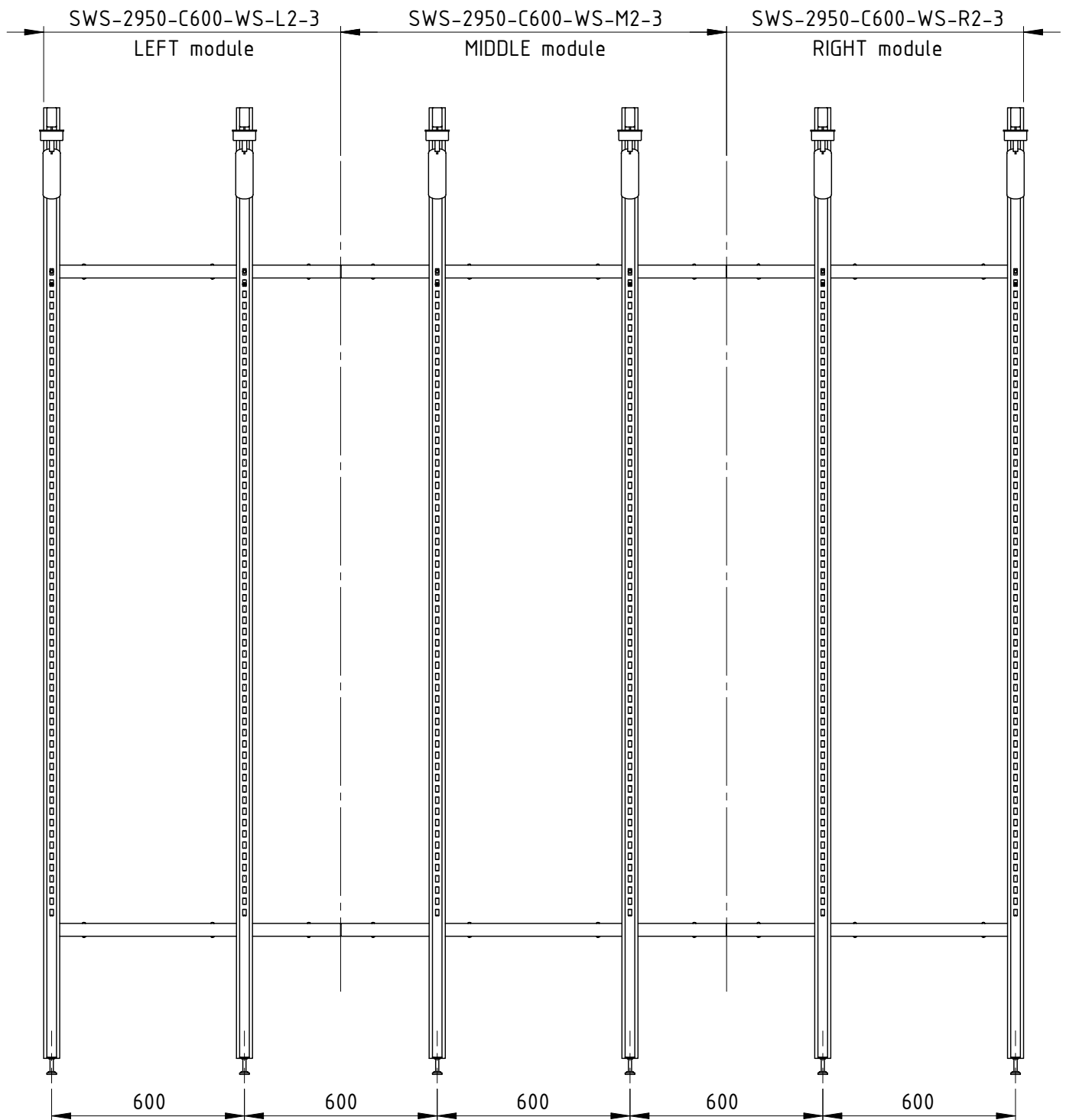

- SWS** : Shelving Wall System
2950 : Vertical rail height 2950mm
C600 : With down light console, length 600mm
WS : With wooden sides
600 : Vertical rails axial distance 600mm
L2/M2/R2 : Left, middle and right modules with two vertical rails
3 : White surface finish (RAL 9010 matte)

EXAMPLE 5

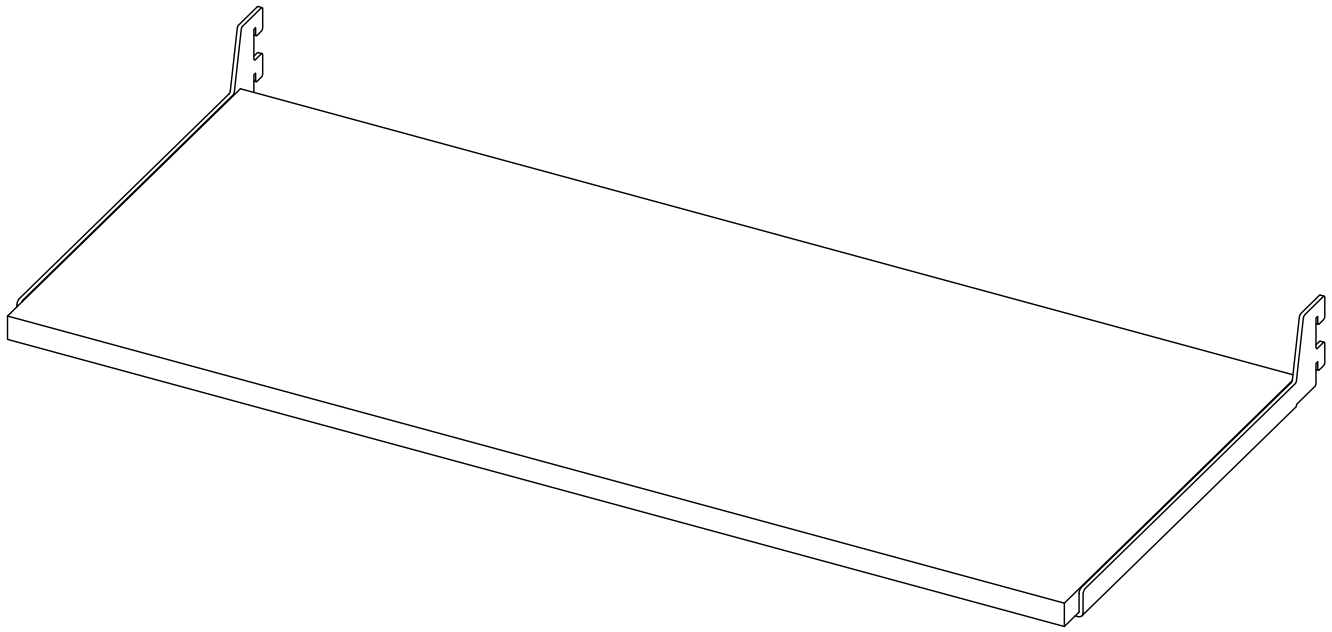

- Wood shelf -

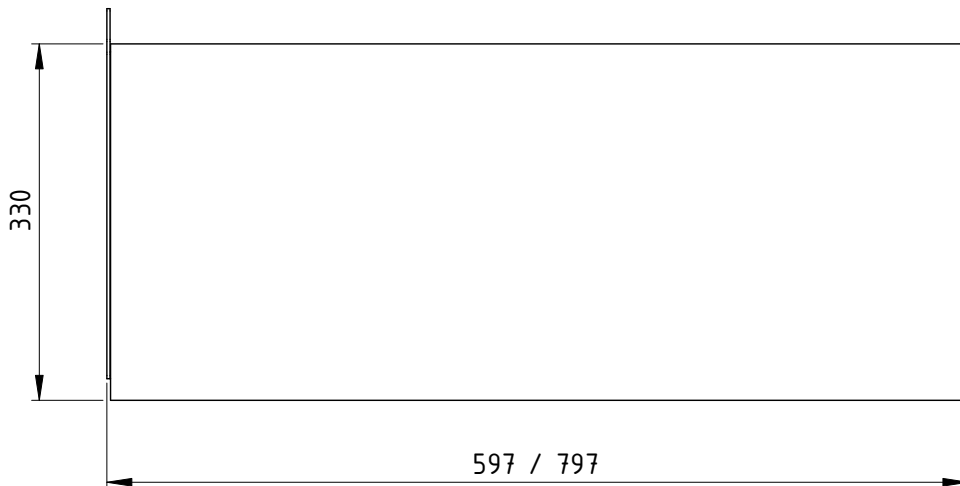
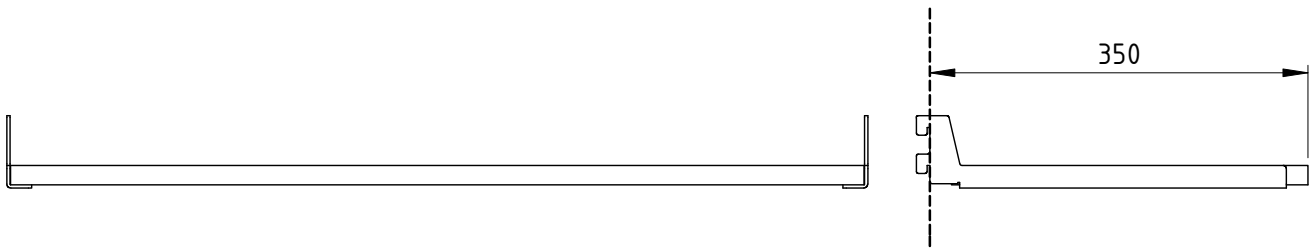

Wood material as per client's request.

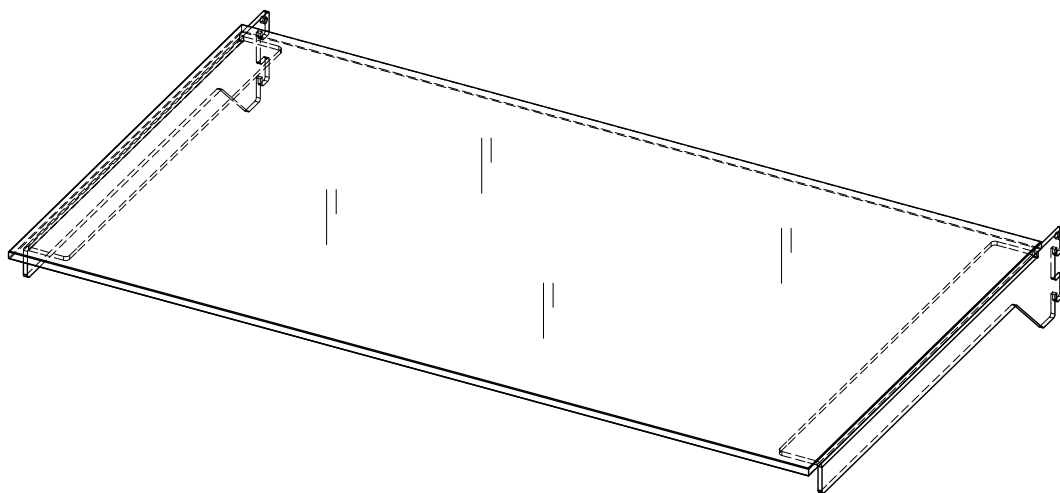

- Glass shelf -

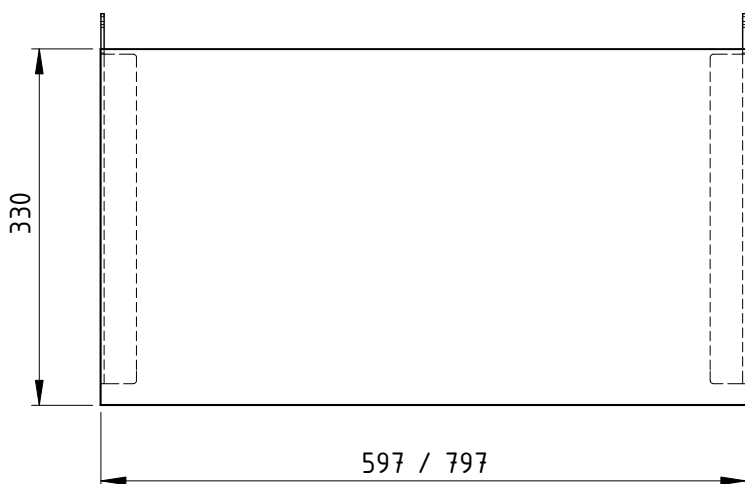
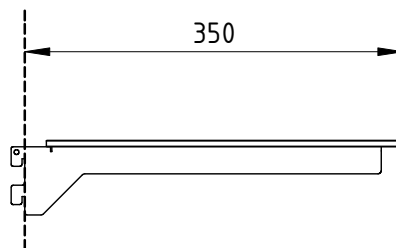

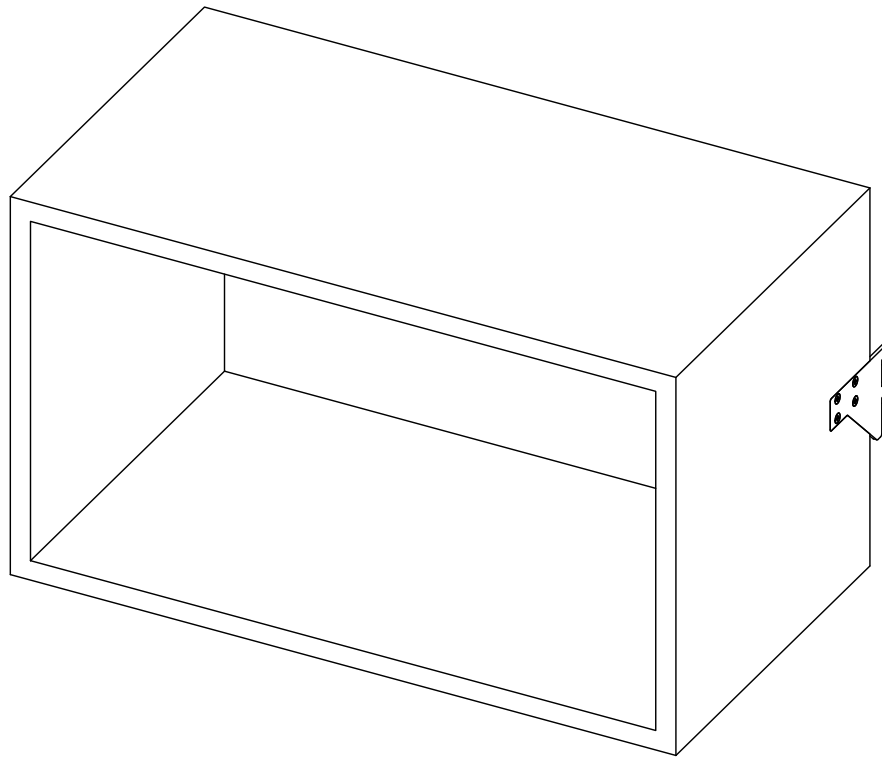

- Wood box shelf -

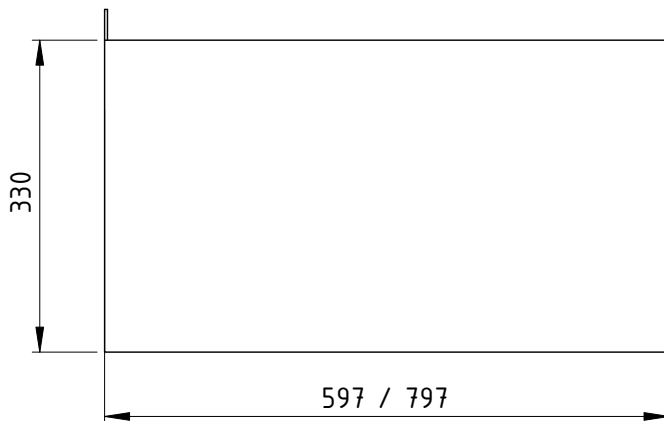
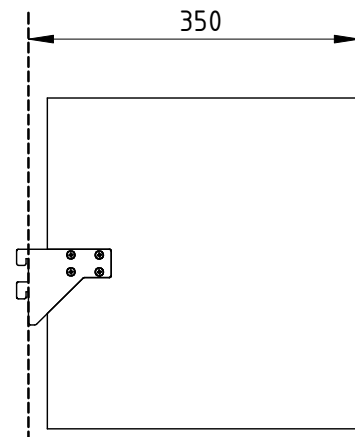
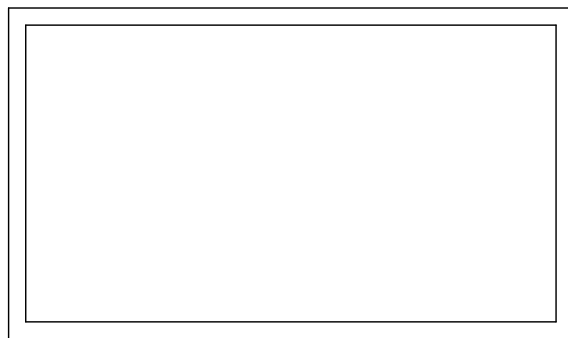

Wood material as per client's request.

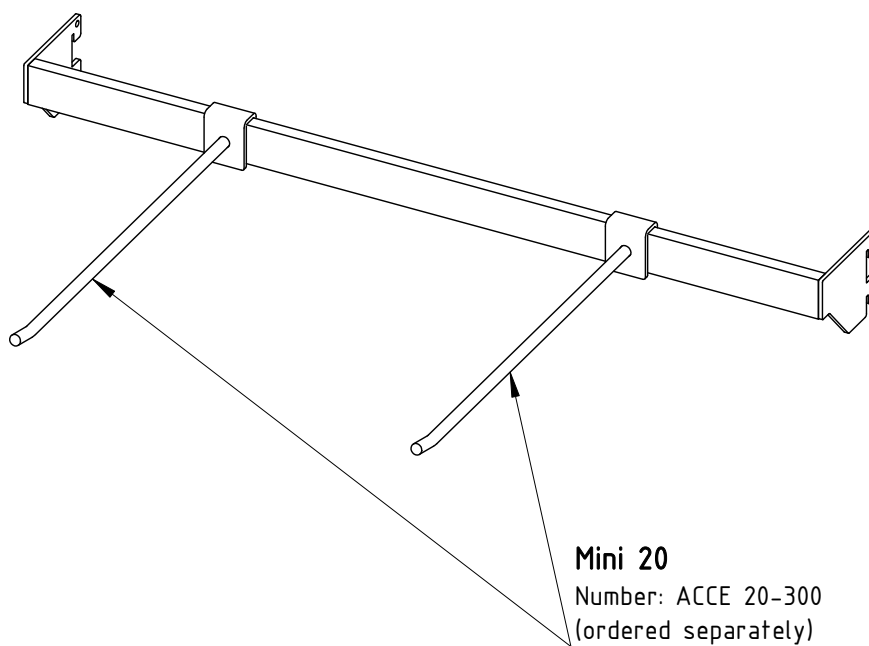

- Hanger Support 1 -

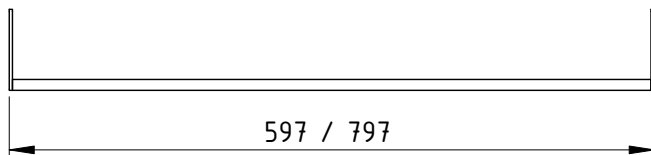
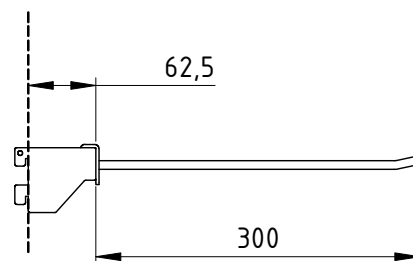
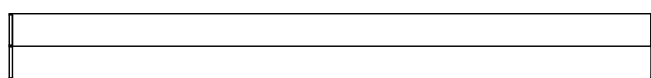

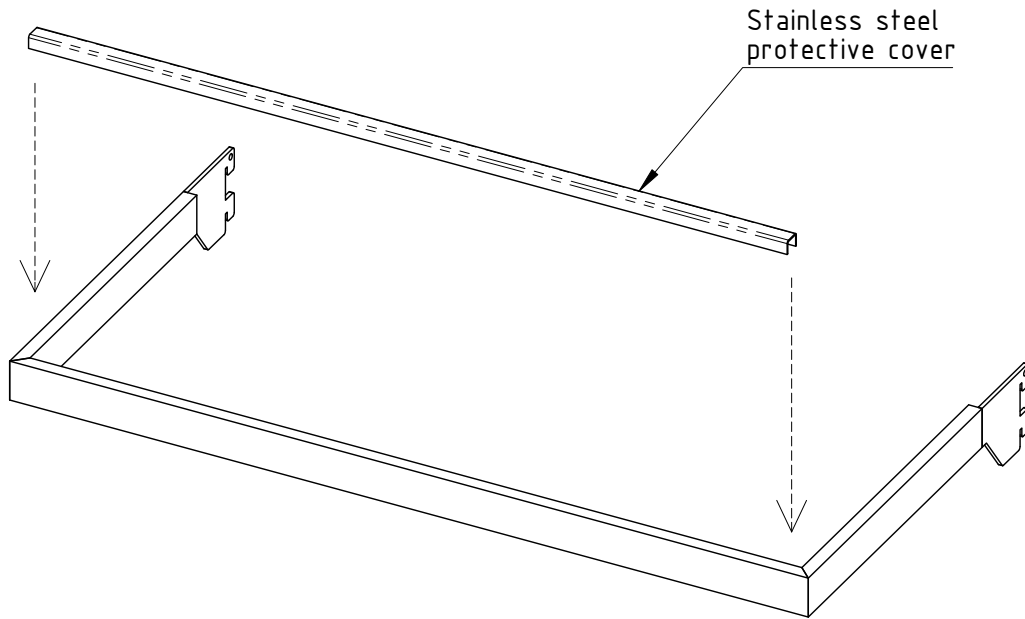

Stainless steel protective cover

- Hanger Support 2 -

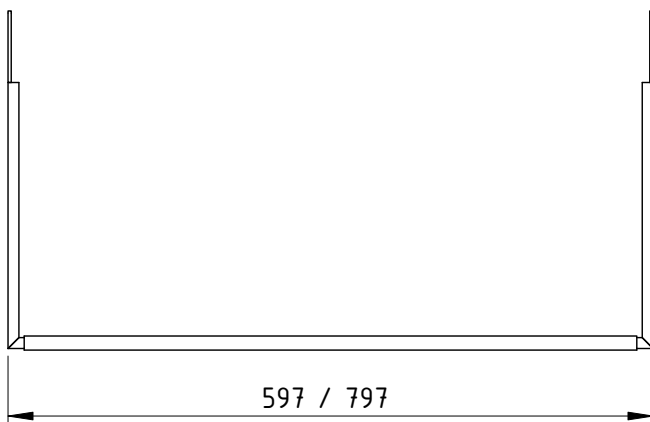
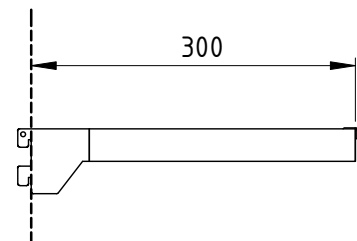
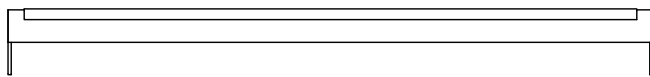

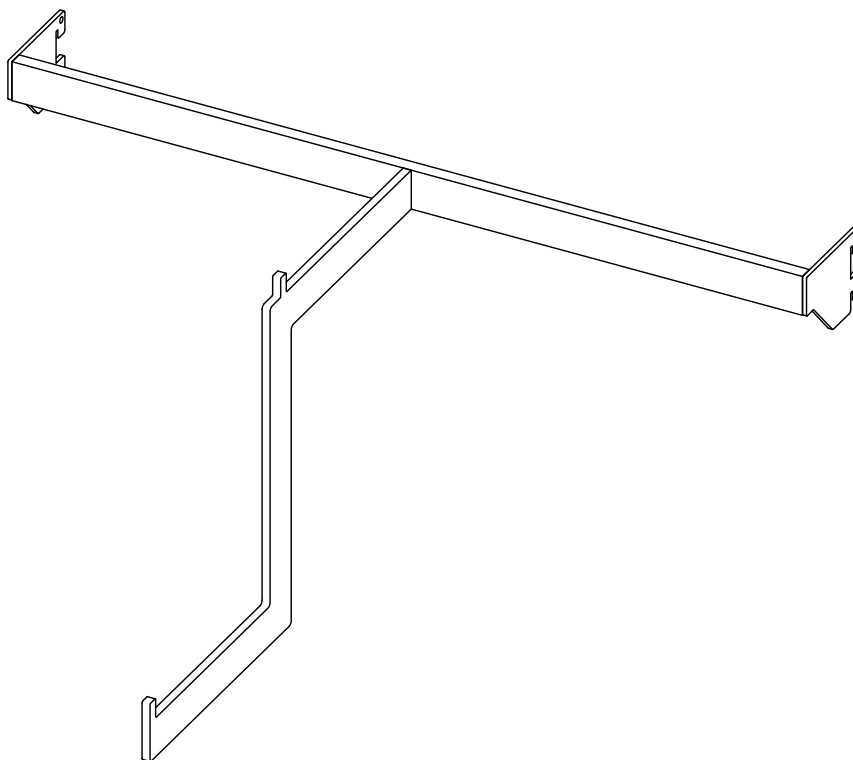

- Hanger Support 45 -

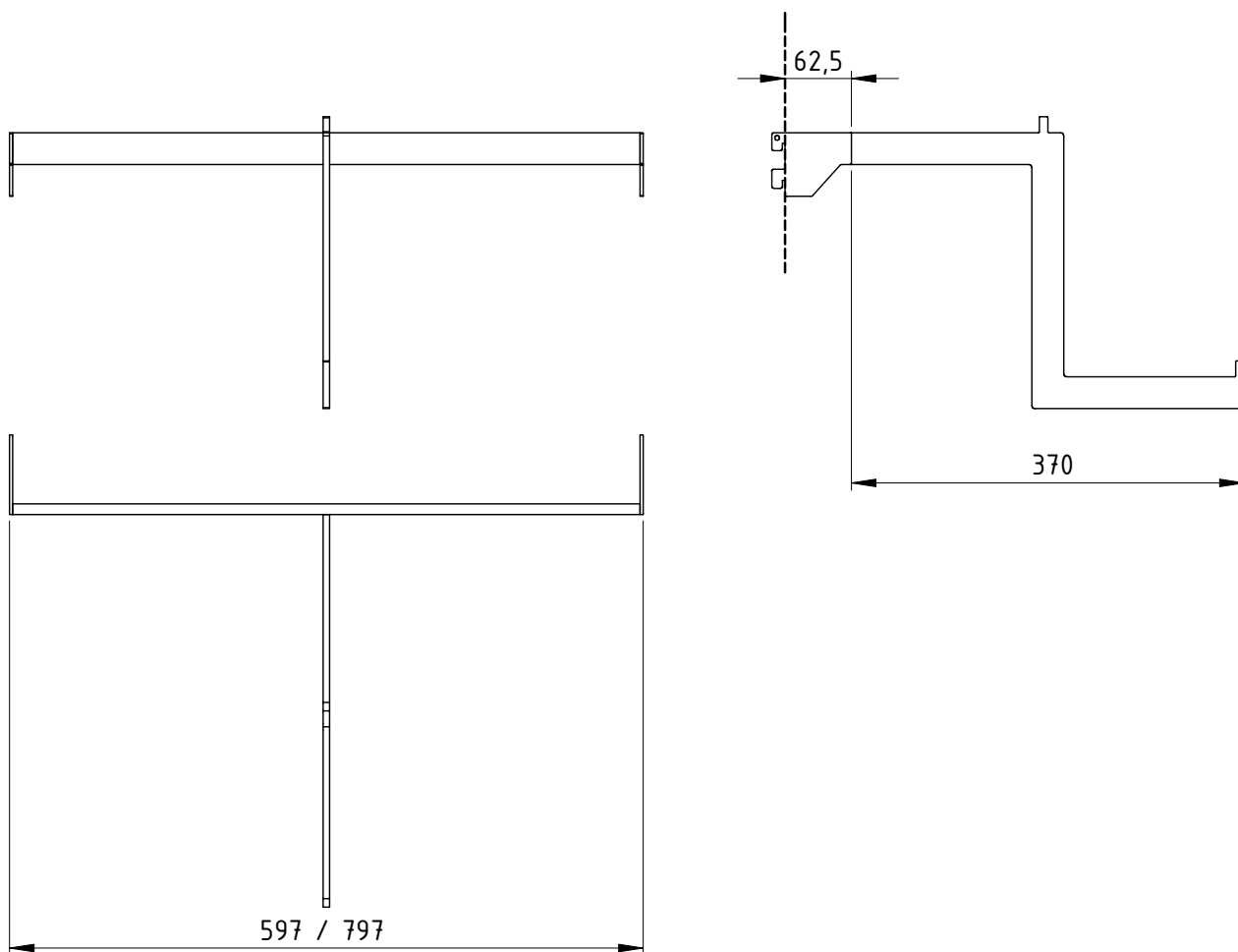

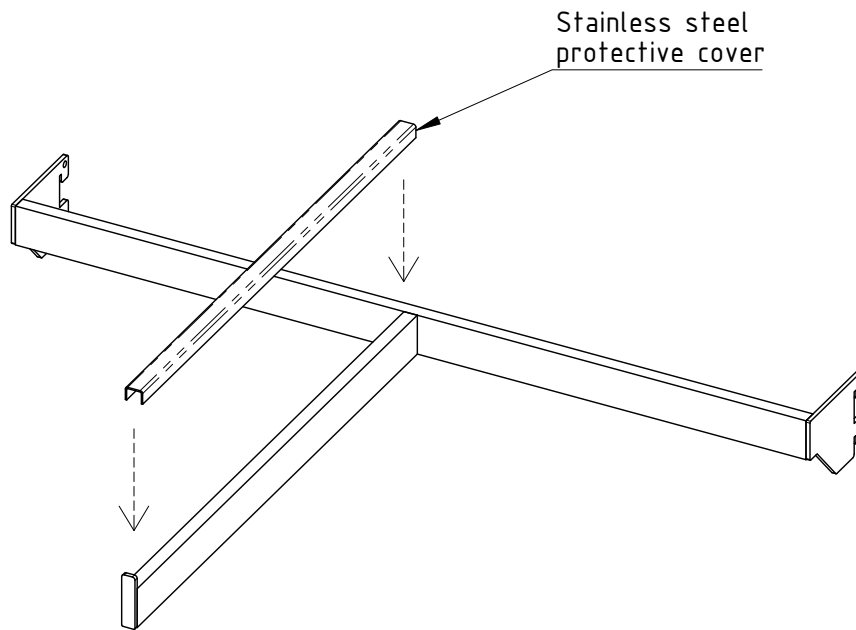

Stainless steel protective cover

- Hanger Support 46 -

